

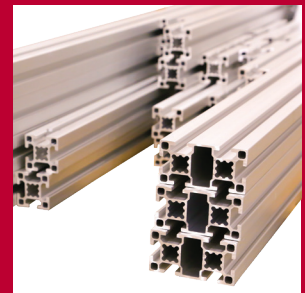

a coesia brand



STRUCTURAL FRAMING COMPONENTS

TABLE OF CONTENTS

EXTRUDED PROFILES	PAGE #	PART No.	CONNECTION PLATES (CONT'D)	PAGE #	PART No.
40 X 40 4 Slot	6	372000000	80 X 80 Connection Plate	28	BCPA076076
40 X 40 3 Slot	7	375000000	45 X 90 Connection Plate	28	BCPS045090
40 X 40 Corner 2 Slot	8	366000000	90 X 90 Connection Plate	28	BCPA086086
40 X 80 6 Slot	9	373000000			
40 X 80 5 Slot	10	376000000	SWIVEL JOINTS	PAGE #	PART No.
40 X 80 Corner 3 Slot	11	367000000	40 X 40 Pivot Joint	29	BPJA40040
80 X 80 8 Slot	12	374000000	40 X 40 Pivot Joint w/ Locking Lever	29	BLPJZ040040
80 X 80 Corner 4 Slot	13	377000000	40 X 80 Pivot Joint	29	BPJZ040080
80 X 80 Linear Bearing Housing 4 Slot	14	260000000	40 X 80 Pivot Joint w/ Locking Lever	29	BLPJZ080040
45 X 45 4 Slot	15	363000000	45 X 45 Pivot Joint	30	BPJA045045
45 X 90 6 Slot	16	364000000	45 X 45 Pivot Joint w/ Locking Lever	30	BLPJZ045045
90 X 90 8 Slot	17	365000000	45 X 90 Pivot Joint	30	BPJA045090
45 X 60 4 Slot	18	272000000	45 X 90 Pivot Joint w/ Locking Lever	30	BLPJZ045090
30 X 30 Mesh 2 Slot	19	275000000			
30 X 45 Mesh 2 Slot	20	276000000	BRACKETS	PAGE #	PART No.
32 X 86 2 Slot	21	243000000	20mm 60 X 49 Suspension Bracket	31	BSBZ060020049
19 X 42 4 Slot	22	253000000			
Tool Rail 1 Slot	23	368000000	CONNECTORS	PAGE #	PART No.
			40mm Connector	32	CFUCS525019023
GUSSET BRACKETS	PAGE #	PART No.	40mm Longitudinal Connector	32	CFDCS086019023
39 X 39 X 40 Gusset	24	BGZ039039040	40mm Threaded Connector	32	CFTCS056016023M08
76 X 76 X 38 Gusset	24	BGA076038076			
76 X 76 X 74 Gusset	24	BGZ076074076	FASTENERS	PAGE #	PART No.
42 X 42 X 42 Gusset	24	BGA042042042	M8 X 20mm Hammer Head	33	CFHHS020M8
86 X 86 X 43 Gusset	25	BGA086043086	M8 X 25mm Hammer Head	33	CFHHS025M8
86 X 86 X 88 Gusset	25	BGA086088086			
40 X 40 X 80 Gusset	25	BGS040040080	THREADED INSERTS	PAGE #	PART No.
100 X 100 X 30 Gusset	25	BGS100100030	M6 Threaded Insert	34	CFIS020M15M06
			M8 Threaded Insert	34	CFIS020M15M08
ANGLE CONNECTION BRACKETS	PAGE #	PART No.	M10 Threaded Insert	34	CFIS020M15M10
40 X 40 45° Angle Connector	26	BCAZ052040040045			
80 X 45 45° Angle Connector	26	BCAA051080040045	FASTENING ELEMENTS	PAGE #	PART No.
40 X 80 45° Angle Connector	26	BCAZ085040080045	M4 Roll-In Spring Leaf T-Nut Slot 10	35	CFSL019010M4
45 X 45 45° Angle Connector	26	BCAA054045045045	M5 Roll-In Spring Leaf T-Nut Slot 10	35	CFSL019010M5
90 X 45 45° Angle Connector	27	BCAA054090045045	M6 Roll-In Spring Leaf T-Nut Slot 10	35	CFSL019010M6
			M8 Roll-In Spring Leaf T-Nut Slot 10	35	CFSL019010M8
CONNECTION PLATES	PAGE #	PART No.	M8 X 1.25 Hi-Torque T-Nut	36	CFHTS019010M08
40 X 80 Connection Plate	28	BCPS040080	8mm Threaded Key Nut Slot 10	36	CFKNS020010M08

TABLE OF CONTENTS

FASTENING ELEMENTS (CONT'D)	PAGE #	PART NO.	FEET (CONT'D)	PAGE #	PART NO.
8mm Threaded 200mm Splice Nut	36	CFSNS200010M08	100mm Rubber Swivel Caster	46	FSCATR032100
M5 Insert Nut	36	CFTPS019019004M05	100mm 3/8" Rubber Rigid Caster	46	FRCATR100
M6 Insert Nut	37	CFTPS019019004M06	125mm Rubber Rigid Caster	46	FRCATR032125
M8 Insert Nut	37	CFTPS019019004M08	4" Floor Lock Lift	46	FLLS0450046
FEET	PAGE #	PART NO.	PANELS	PAGE #	PART NO.
200mm Floor Mount Foot	38	FBFS200200210M08	12.5Ga 1" Sq. PVC Blk Wire Mesh	47	PWMS096048001
250mm Floor Mount Foot	38	FBFS250250210M08	12.5Ga 1.5" Sq. PVC Blk Wire Mesh	47	PWMS096048015
40mm Floor Mount Base	38	FBF40150150100	4' X 8' 3mm Silver Metallic Signabond	47	PSGA096048003
45mm Floor Mount Base	38	FBF45150150100	4' X 8' 4mm Poly-Carb	47	PCPPC096048004
160mm Adjusting Foot w/out Screw	39	FAFZ160038060	4' X 8' 3mm Smoked Poly-Carb Panel	48	PSPPC096048003
160mm Adjusting Foot w/ Screw	39	FAFSZ160038060	4' X 8' 6mm White Sintra	48	PPWS096048006
Base Angle Foot	39	FBFS088039200M08	4' X 8' 6mm Black Sintra	48	PPBS096048006
M16 40 X 80 Base Plate	39	FBPZ040080016M16	Spring Clip	48	PSCS20010
M16 80 X 80 Base Plate	40	FBPZ080080016M16	Gray Slot Cover	49	PSCGP02M010075
M16 45 X 90 Base Plate	40	FBPZ045090016M16	Yellow Slot Cover	49	PSCYP02M010075
M16 90 X 90 Base Plate	40	FBPZ090090016M16	Door Seal	49	PDSR075010
15mm Ball Threaded Rod - Swivel Foot	40	FTRS100M16			
15mm Ball Threaded Rod - Swivel Foot	41	FTRS125M16	ELECTRICAL ACCESSORIES	PAGE #	PART NO.
15mm Ball Threaded Rod - Swivel Foot	41	FTRS150M16	40 X 40 Gray Wire Way for 8mm Slot	50	PWGP008040040008
15mm Ball Threaded Rod - Swivel Foot	41	FTRS200M16	40 X 40 Black Wire Way for 8mm Slot	50	PWBP008040040008
40mm Plastic Swivel Foot	41	FPSP039018	40 X 40 Gray Wire Way for 10mm Slot	50	PWGP008040040010
40mm Steel Swivel Foot	42	FPSS039018	40 X 40 Black Wire Way for 10mm Slot	50	PWBP008040040010
Anti-Slip Pad for 40mm Swivel Foot	42	FASR030007	40 X 40 Gray Wire Way	51	PWGP008040040000
80mm Plastic Swivel Foot	42	FPSP079018	45 X 45 Gray Wire Way for 10mm Slot	51	PWGP008045045010
80mm Steel Swivel Foot	42	FPSS079018	MMI Box	51	
Anti-Slip Pad for 80mm Swivel Foot	43	FASR068007	Cable Binding Box	51	PBBP017017021
45mm Plastic Swivel Foot	43	FPSP044018			
45mm Steel Swivel Foot	43	FPSS044018	HARDWARE	PAGE #	PART NO.
Anti-Slip Pad for 45mm Swivel Foot	43	FASR035007	40 X 40 Black Cap	52	HCP040040
80mm Plastic Swivel Foot w/ M8 Holes	44	FPSHP079018	40 X 80 Black Cap	52	HCP040080
80mm Plastic Teardrop Swivel Foot	44	FPSTP133079019	80 X 80 Black Cap	52	HCP080080
50mm Polyurethane Caster	44	FRCAPU019050	40mm Profile Hinge	52	HHGZ225040024M08
50mm Polyurethane Swivel Caster	44	FSCAPU019050	40 X 80 Profile Hinge	53	HHGZ080040024M08
75mm Rigid Rubber Caster	45	FRCATR032075	45mm Profile Hinge	53	HHGZ250040024M08
75mm Rubber Swivel Caster	45	FSCATR032075	45mm Heavy Duty Profile Hinge	53	HHGP090040017M06
75mm Rubber Swivel Caster w/ Brake	45	FSLCATR032075	Bridge Handle	53	HBHP142026040M06
100mm Rubber Rigid Caster	45	FRCATR032100	Comfort Handle	54	HCHP236038075M08

TABLE OF CONTENTS

HARDWARE (CONT'D)	PAGE #	PART NO.			
Machine Handle	54	HMP240080100M08			
LH L-Handle w/out Lock	54	HLHP127025039			
RH L-Handle w/out Lock	54	HRHP127025039			
40mm Wire Mesh Panel Holder	55	HPRA078040016M08			
45mm Wire Mesh Panel Holder	55	HPRA088045017M08			
12" Door Rod Latch	55	HRLS012			
24" Door Rod Latch	55	HRLS024			
36" Door Rod Latch	56	HRLS036			
48" Door Rod Latch	56	HRLS048			
Pivot Angle	56	HPAS130030087M08			
Anti-Twist Clip	56	HATS025019010			
Bullet Catch	57	HBC047028020M6			
Magnet Catch	57	HMC040028020M6			
Door Slide Lock	57	HSL078038016M6			
MMI FORM	58				

* Please visit our website www.amcautomation.com for additional information on all of our available products.

EXTRUDED PROFILES

PART #	DESCRIPTION
372000000	40 x 40 4 Slot

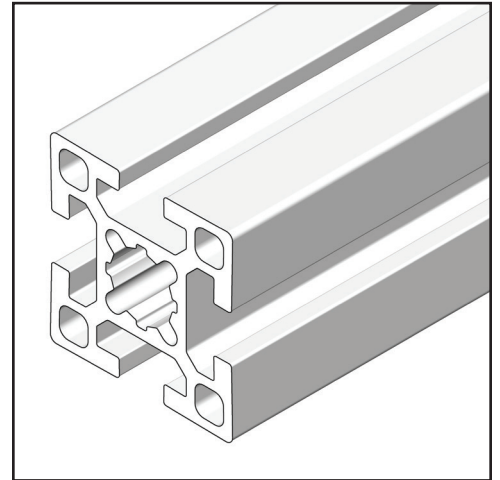
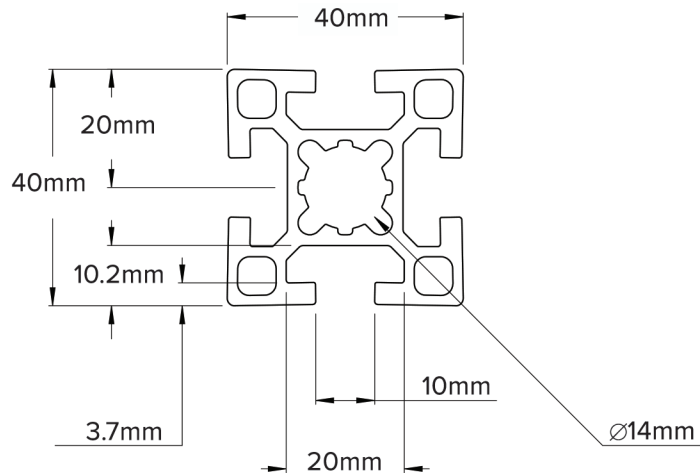

Moments of Inertia (Lx) (cm ⁴)	Moments of Inertia (Ly) (cm ⁴)	Moments of Resistance (Wx) (cm ³)	Moments of Resistance (Wy) (cm ³)	Weight (kg/m)
9.44	9.44	4.72	4.72	1.56

EXTRUDED PROFILES

PART #	DESCRIPTION
375000000	40 x 40 3 Slot

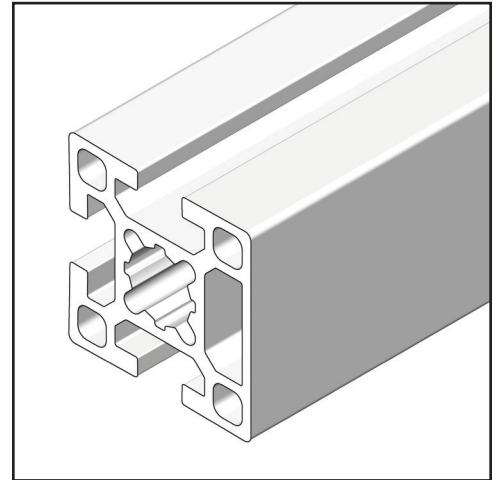
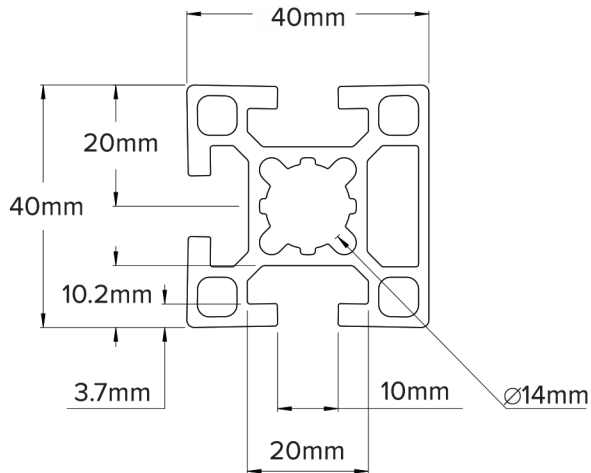

Moments of Inertia (Lx) (cm ⁴)	Moments of Inertia (Ly) (cm ⁴)	Moments of Resistance (Wx) (cm ³)	Moments of Resistance (Wy) (cm ³)	Weight (kg/m)
9.35	9.53	4.68	4.77	1.56

EXTRUDED PROFILES

PART #	DESCRIPTION
366000000	40 x 40 Corner 2 Slot

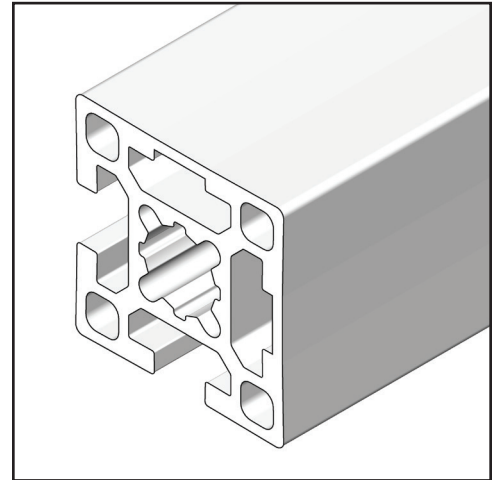
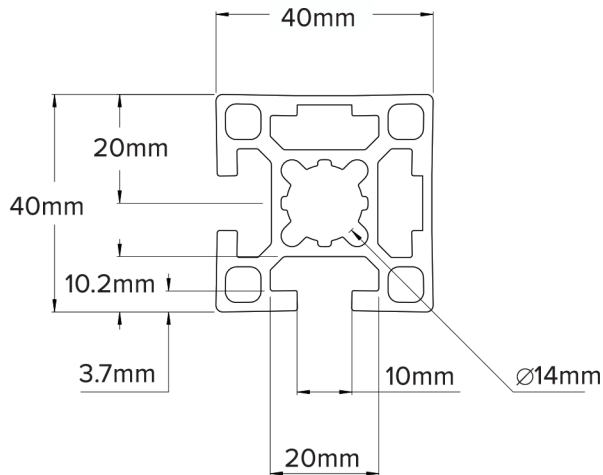

Moments of Inertia (Lx) (cm ⁴)	Moments of Inertia (Ly) (cm ⁴)	Moments of Resistance (Wx) (cm ³)	Moments of Resistance (Wy) (cm ³)	Weight (kg/m)
10.06	10.06	5.03	5.03	1.66

EXTRUDED PROFILES

PART #	DESCRIPTION
373000000	40 x 80 6 Slot

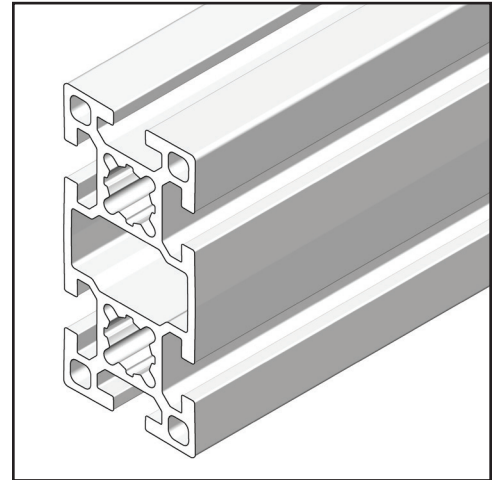
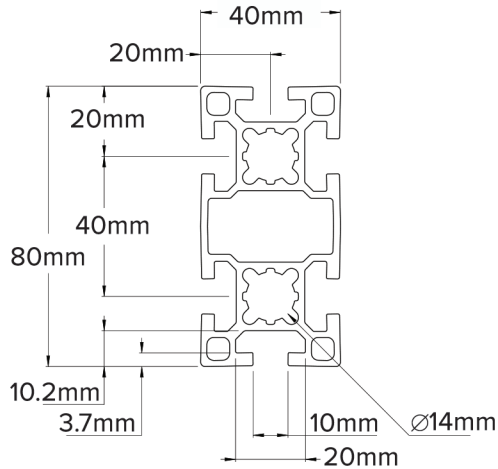

Moments of Inertia (Lx) (cm ⁴)	Moments of Inertia (Ly) (cm ⁴)	Moments of Resistance (Wx) (cm ³)	Moments of Resistance (Wy) (cm ³)	Weight (kg/m)
64.91	16.89	16.23	8.45	2.63

EXTRUDED PROFILES

PART #	DESCRIPTION
376000000	40 x 80 5 Slot

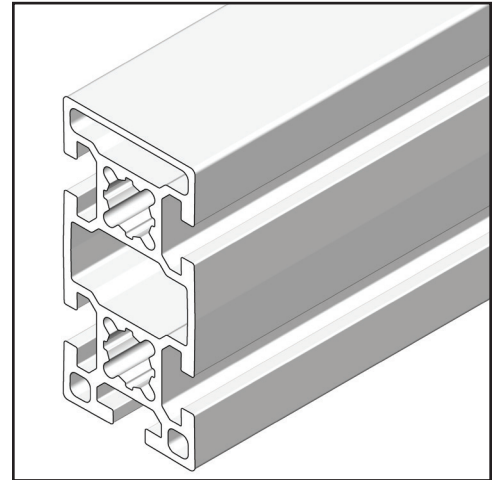
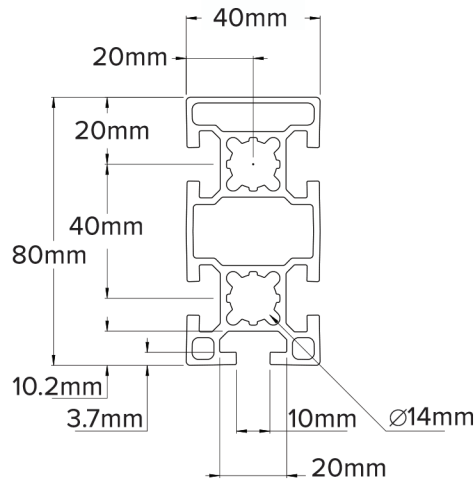

Moments of Inertia (Lx) (cm ⁴)	Moments of Inertia (Ly) (cm ⁴)	Moments of Resistance (Wx) (cm ³)	Moments of Resistance (Wy) (cm ³)	Weight (kg/m)
60.91	16.41	14.78	8.21	2.54

EXTRUDED PROFILES

PART #	DESCRIPTION
367000000	40 x 80 Corner 3 Slot

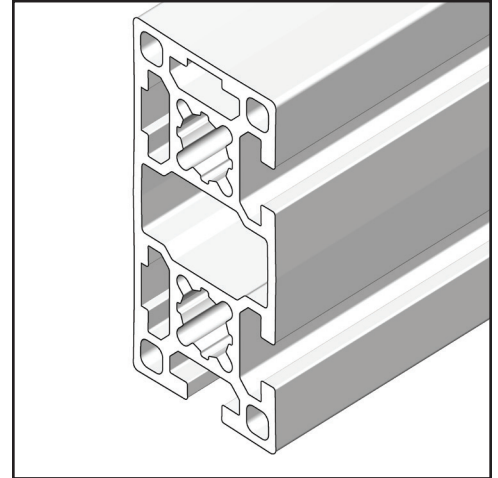
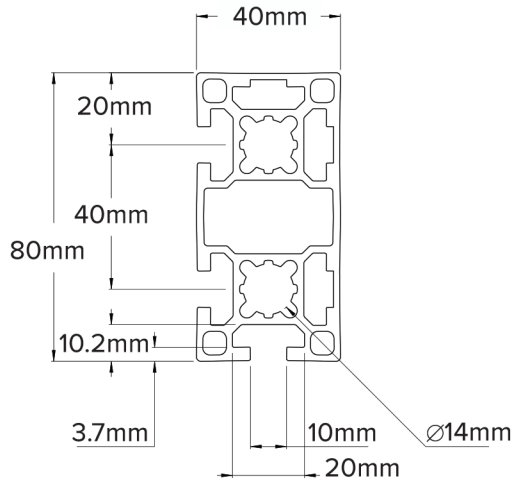

Moments of Inertia (Lx) (cm ⁴)	Moments of Inertia (Ly) (cm ⁴)	Moments of Resistance (Wx) (cm ³)	Moments of Resistance (Wy) (cm ³)	Weight (kg/m)
68.87	18.09	16.96	9.05	2.77

EXTRUDED PROFILES

PART #	DESCRIPTION
374000000	80 x 80 8 Slot

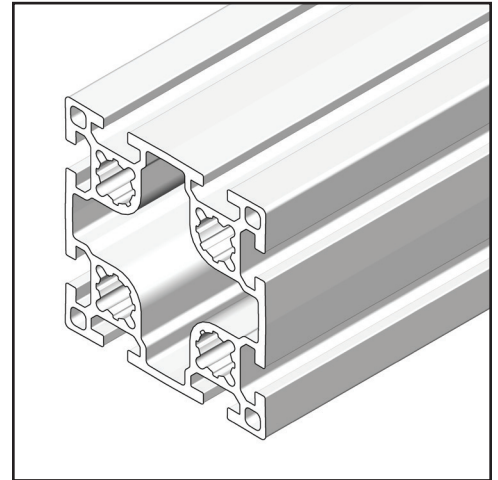
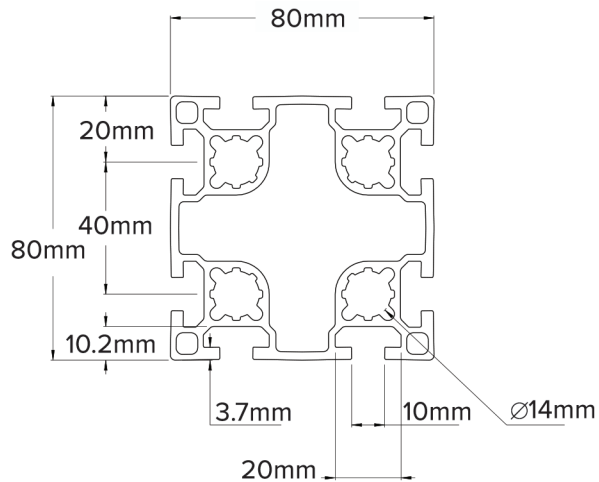

Moments of Inertia (Lx) (cm ⁴)	Moments of Inertia (Ly) (cm ⁴)	Moments of Resistance (Wx) (cm ³)	Moments of Resistance (Wy) (cm ³)	Weight (kg/m)
113.79	113.79	28.45	28.45	4.22

EXTRUDED PROFILES

PART #	DESCRIPTION
377000000	80 x 80 Corner 4 Slot

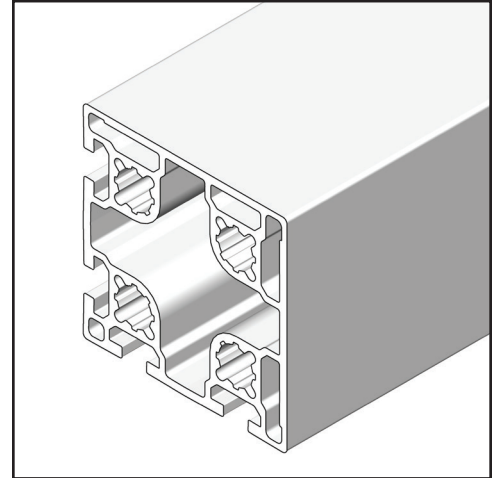
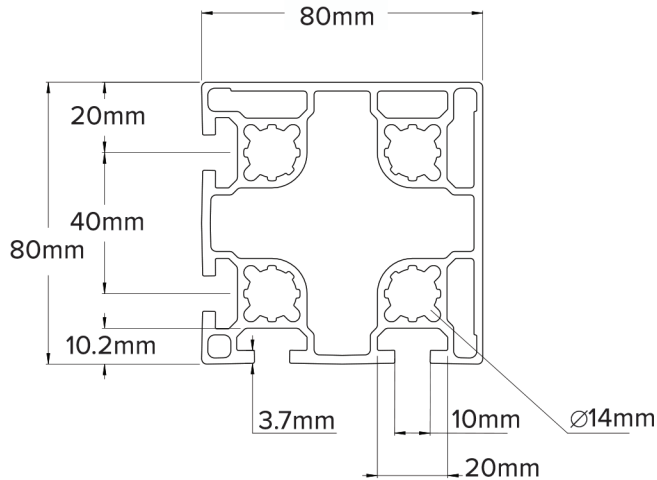

Moments of Inertia (Lx) (cm ⁴)	Moments of Inertia (Ly) (cm ⁴)	Moments of Resistance (Wx) (cm ³)	Moments of Resistance (Wy) (cm ³)	Weight (kg/m)
115.58	115.58	28.57	28.57	4.27

EXTRUDED PROFILES

PART #	DESCRIPTION
260000000	80 x 80 Linear Bearing Housing 4 Slot

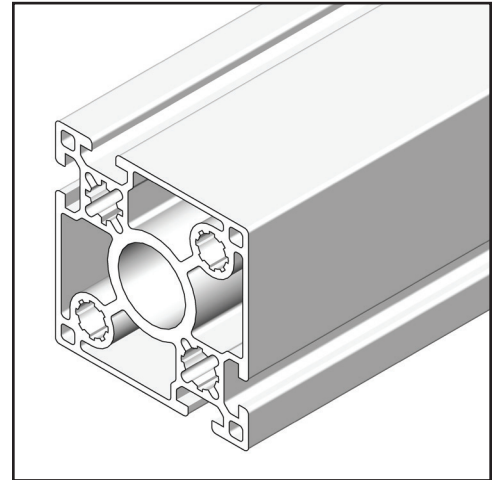
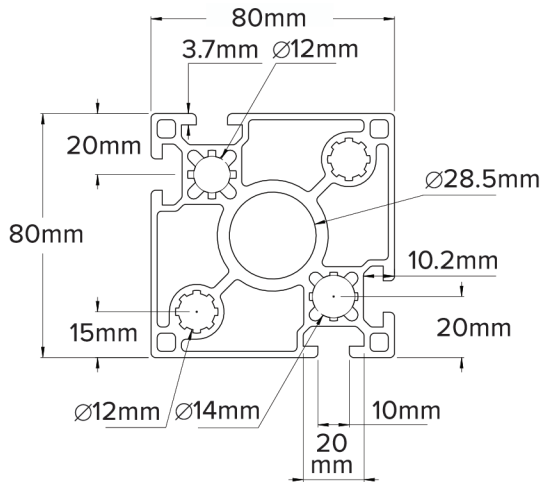

Moments of Inertia (Lx) (cm ⁴)	Moments of Inertia (Ly) (cm ⁴)	Moments of Resistance (Wx) (cm ³)	Moments of Resistance (Wy) (cm ³)	Weight (kg/m)
117.72	119.40	22.22	14.93	5.04

EXTRUDED PROFILES

PART #	DESCRIPTION
363000000	45 x 45 4 Slot

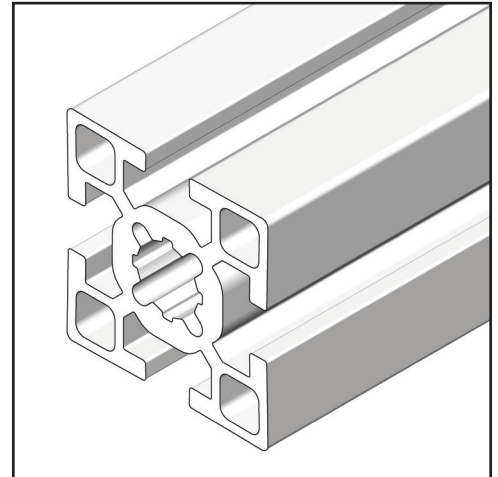
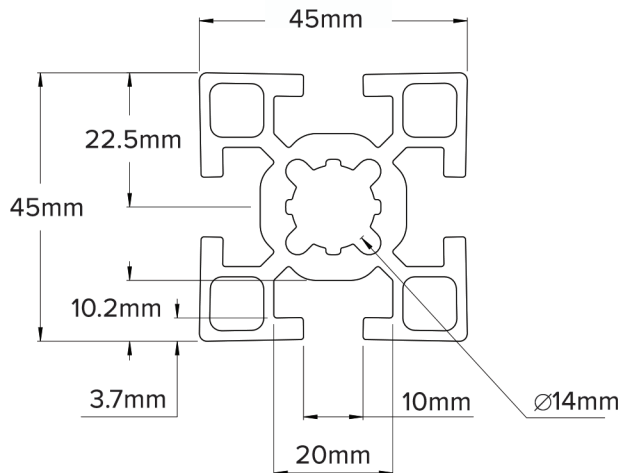

Moments of Inertia (Lx) (cm ⁴)	Moments of Inertia (Ly) (cm ⁴)	Moments of Resistance (Wx) (cm ³)	Moments of Resistance (Wy) (cm ³)	Weight (kg/m)
13.94	13.94	6.20	6.20	2.07

EXTRUDED PROFILES

PART #	DESCRIPTION
364000000	45 x 90 6 Slot

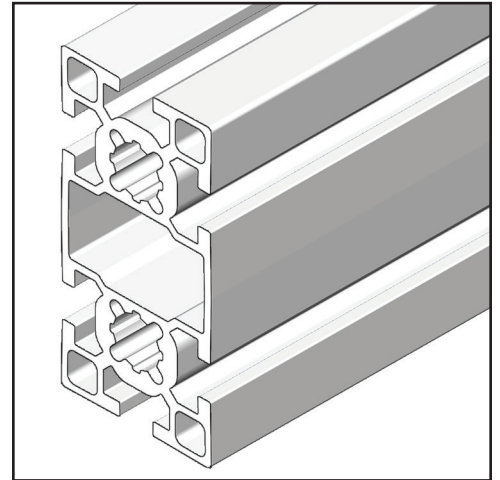
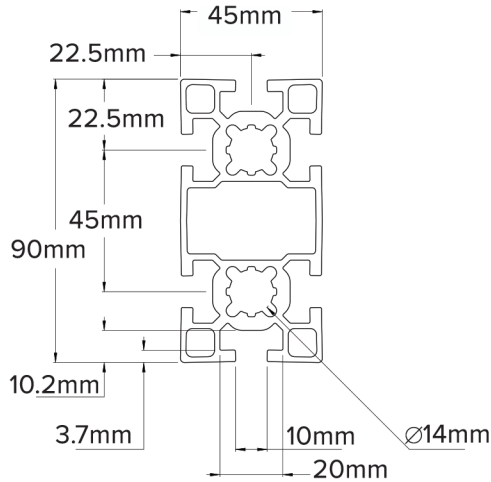

Moments of Inertia (Lx) (cm ⁴)	Moments of Inertia (Ly) (cm ⁴)	Moments of Resistance (Wx) (cm ³)	Moments of Resistance (Wy) (cm ³)	Weight (kg/m)
104.38	25.24	23.20	11.22	3.43

EXTRUDED PROFILES

PART #	DESCRIPTION
365000000	90 x 90 8 Slot

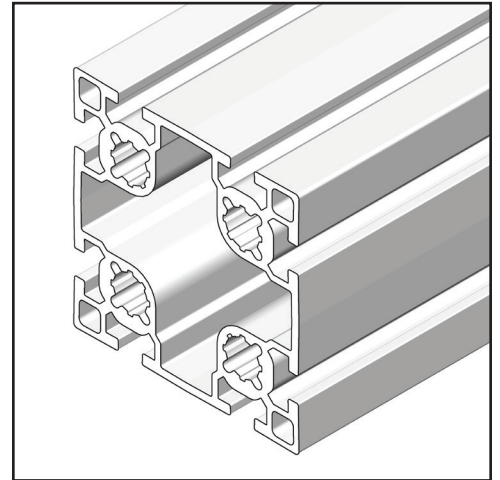
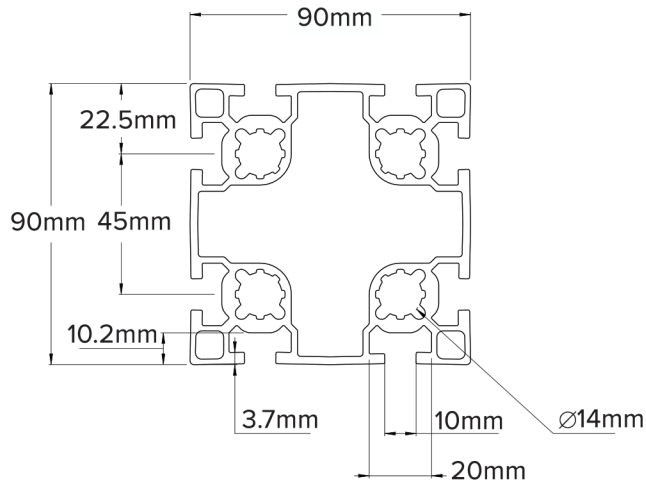

Moments of Inertia (Lx) (cm ⁴)	Moments of Inertia (Ly) (cm ⁴)	Moments of Resistance (Wx) (cm ³)	Moments of Resistance (Wy) (cm ³)	Weight (kg/m)
179.40	179.40	39.87	39.87	5.28

EXTRUDED PROFILES

PART #	DESCRIPTION
272000000	45 x 60 4 Slot

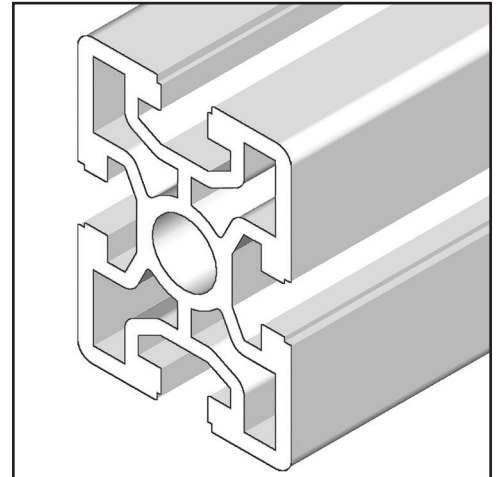
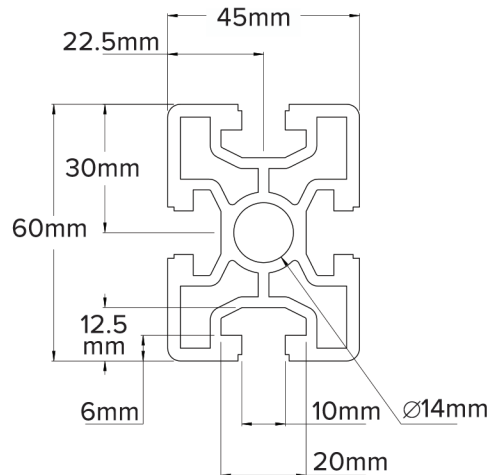

Moments of Inertia (Lx) (cm ⁴)	Moments of Inertia (Ly) (cm ⁴)	Moments of Resistance (Wx) (cm ³)	Moments of Resistance (Wy) (cm ³)	Weight (kg/m)
22.47	37.77	9.99	12.59	2.94

EXTRUDED PROFILES

PART #	DESCRIPTION
275000000	30 x 30 Mesh 2 Slot

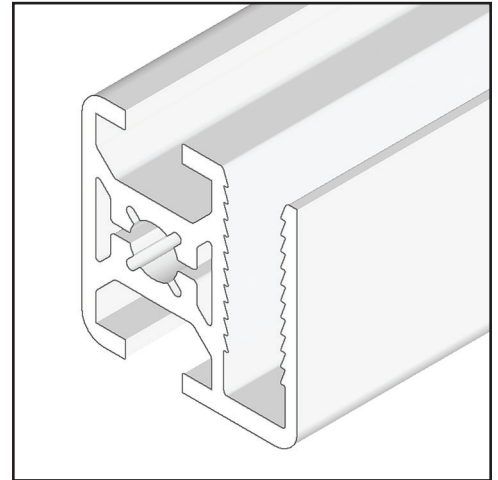
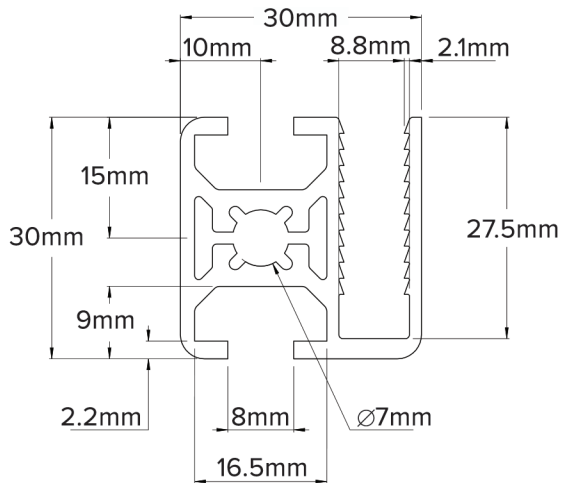

Moments of Inertia (Lx) (cm ⁴)	Moments of Inertia (Ly) (cm ⁴)	Moments of Resistance (Wx) (cm ³)	Moments of Resistance (Wy) (cm ³)	Weight (kg/m)
2.39	3.20	1.48	2.13	0.89

EXTRUDED PROFILES

PART #	DESCRIPTION
276000000	30 x 45 Mesh 2 Slot

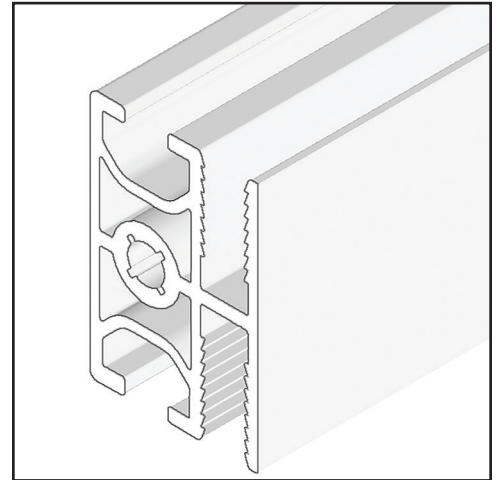
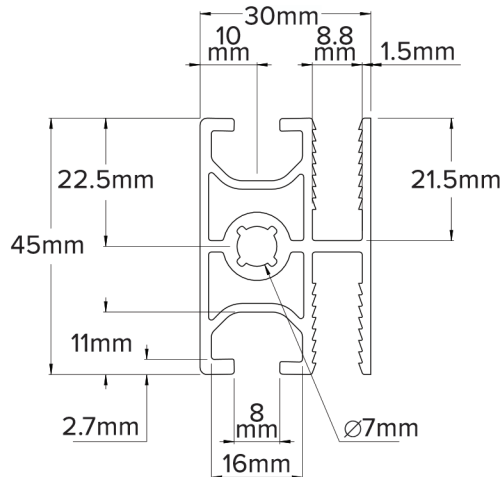

Moments of Inertia (Lx) (cm ⁴)	Moments of Inertia (Ly) (cm ⁴)	Moments of Resistance (Wx) (cm ³)	Moments of Resistance (Wy) (cm ³)	Weight (kg/m)
4.17	6.75	2.64	3.00	1.14

EXTRUDED PROFILES

PART #	DESCRIPTION
243000000	32 x 86 2 Slot

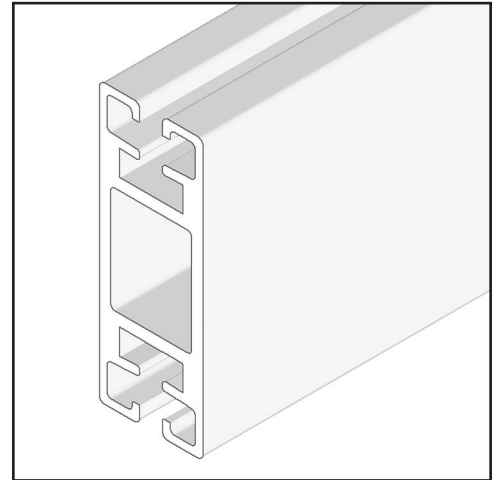
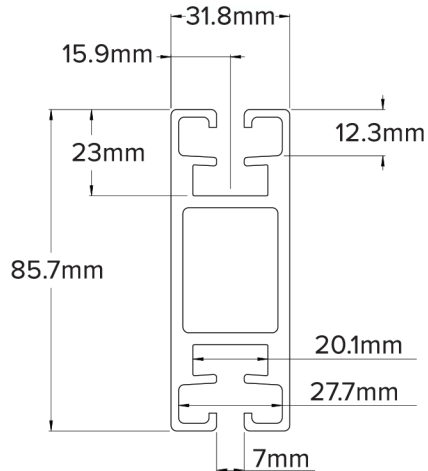

Moments of Inertia (Lx) (cm ⁴)	Moments of Inertia (Ly) (cm ⁴)	Moments of Resistance (Wx) (cm ³)	Moments of Resistance (Wy) (cm ³)	Weight (kg/m)
13.61	61.28	8.57	14.30	2.51

EXTRUDED PROFILES

PART #	DESCRIPTION
253000000	19 x 42 4 Slot

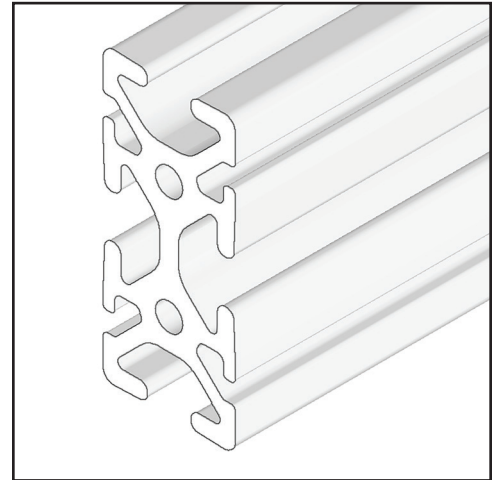
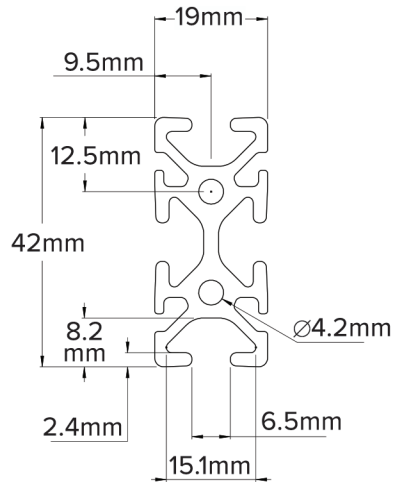

Moments of Inertia (Lx) (cm ⁴)	Moments of Inertia (Ly) (cm ⁴)	Moments of Resistance (Wx) (cm ³)	Moments of Resistance (Wy) (cm ³)	Weight (kg/m)
1.24	5.26	1.64	2.50	0.96

EXTRUDED PROFILES

PART #	DESCRIPTION
368000000	Tool Rail 1 Slot

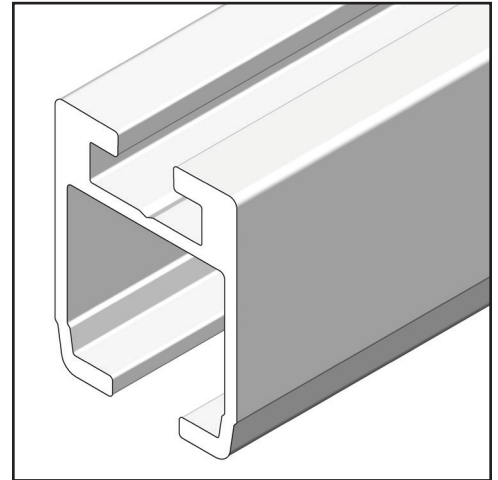
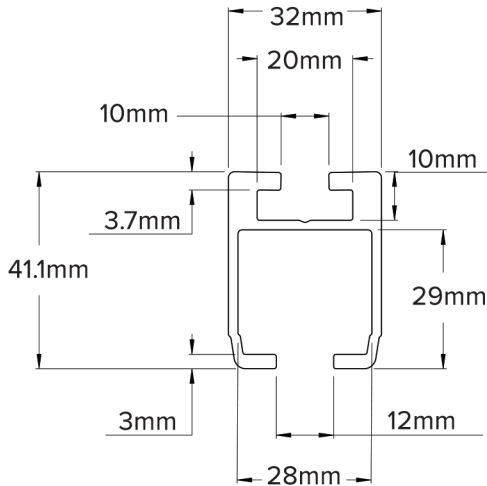

Moments of Inertia (Lx) (cm ⁴)	Moments of Inertia (Ly) (cm ⁴)	Moments of Resistance (Wx) (cm ³)	Moments of Resistance (Wy) (cm ³)	Weight (kg/m)
6.68	5.72	2.66	3.58	1.01

GUSSET BRACKETS

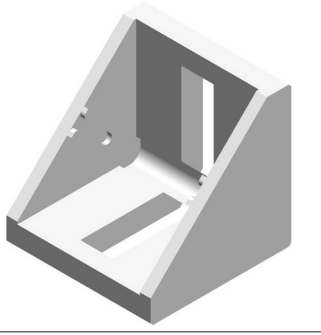
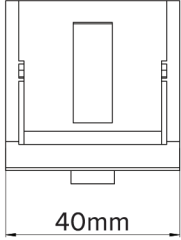
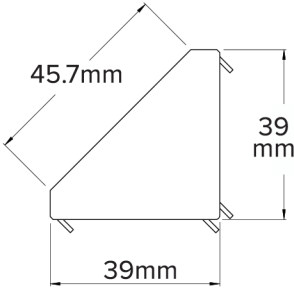
39 X 39 X 40 Gusset
Used to connect two 40mm aluminum profiles at right angles.

Part No. BGZ039039040 **Weight (g)** 99.0

76 X 76 X 38 Gusset
Used to connect two 40 or 80mm aluminum profiles at right angles.

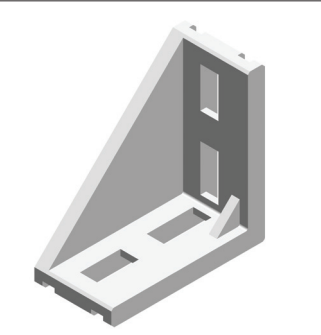
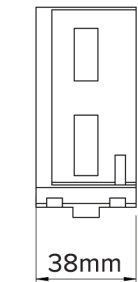
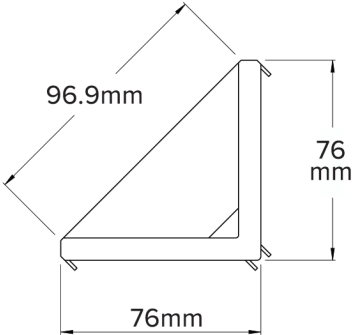
Part No. BGA076038076 **Weight (g)** 118.5

76 X 76 X 74 Gusset
Used to connect two 80mm aluminum profiles at right angles.

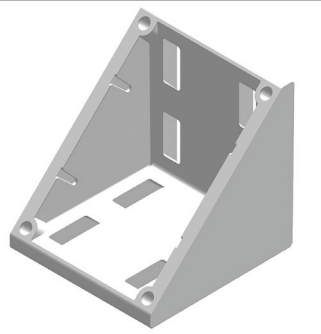
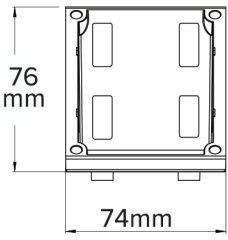
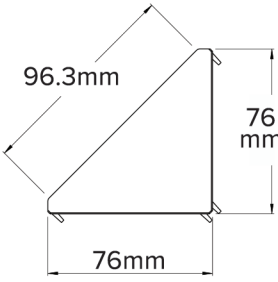
Part No. BGZ076074076 **Weight (g)** 225.0

42 X 42 X 42 Gusset
Used to connect two 45mm aluminum profiles at right angles.

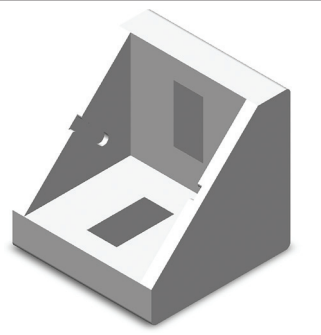
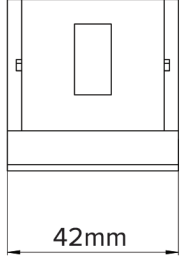
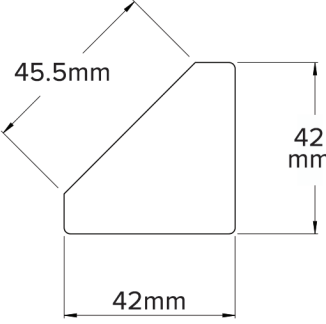
Part No. BGA042042042 **Weight (g)** 56.0

GUSSET BRACKETS

86 X 86 X 43 Gusset
Used to connect two 45mm aluminum profiles at right angles.

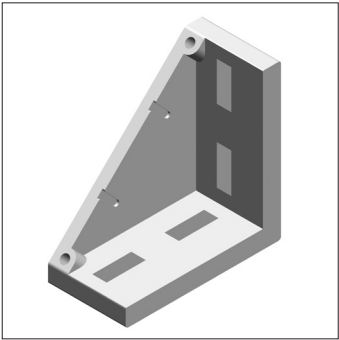
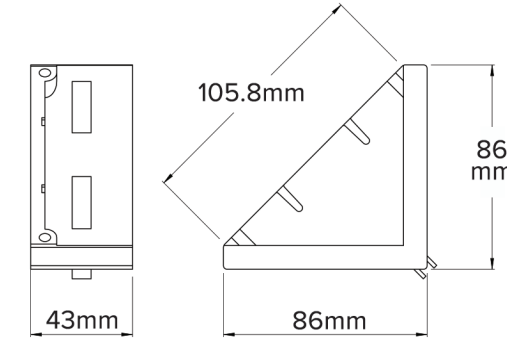
Part No. BGA086043086 **Weight (g)** 163.0

86 X 86 X 88 Gusset
Used to connect two 90mm aluminum profiles at right angles.

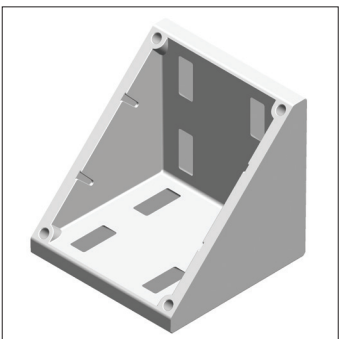
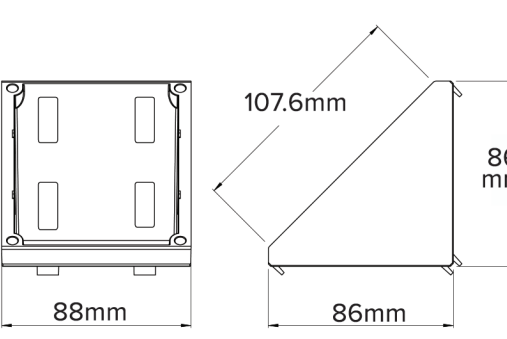
Part No. BGA086088086 **Weight (g)** 358.0

40 X 40 X 80 Gusset
Used to connect two 80mm aluminum profiles at right angles.

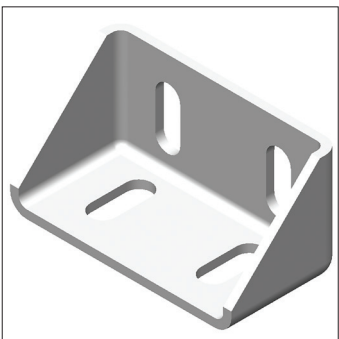
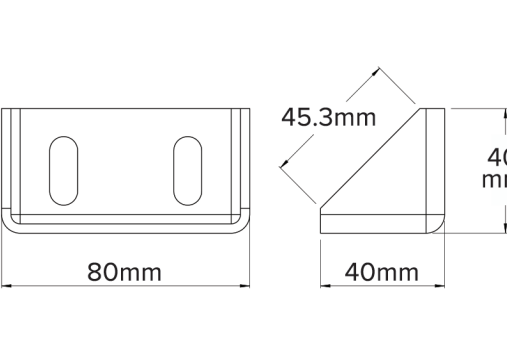
Part No. BGS040040080 **Weight (g)** 158.1

100 X 100 X 30 Gusset
Used to connect two 40mm aluminum profiles at right angles.

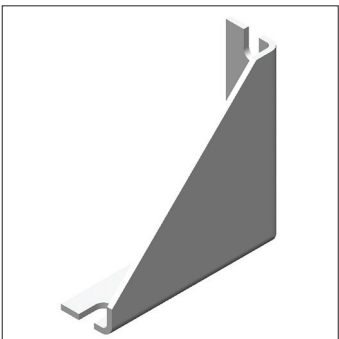
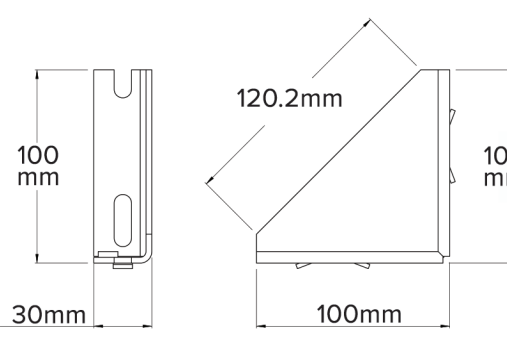
Part No. BGS100100030 **Weight (g)** 252.1



ANGLE CONNECTION BRACKETS

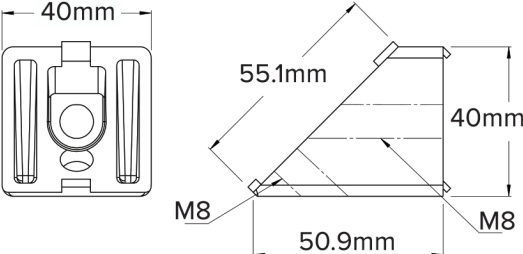
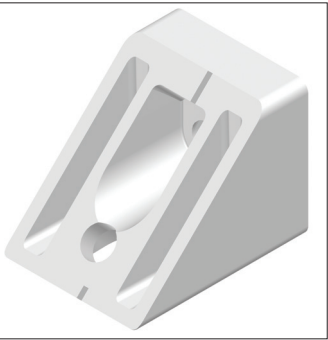

40 X 40 45° Angle Connector
Connects 40mm profile at a 45° angle.

Part No. BCAZ052040040045

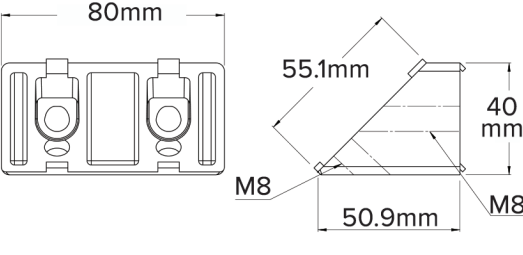

Weight (g) 214.0



80 X 40 45° Angle Connector
Connect 80 x 40mm profile at a 45° angle.

Part No. BCAA051080040045

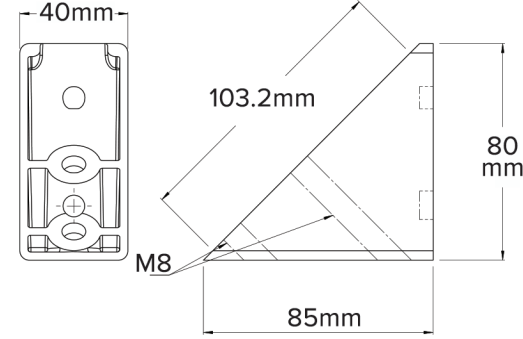

Weight (g) 166.2



40 X 80 45° Angle Connector
Connects 40 x 80mm profile at a 45° angle.

Part No. BCAZ085040080045

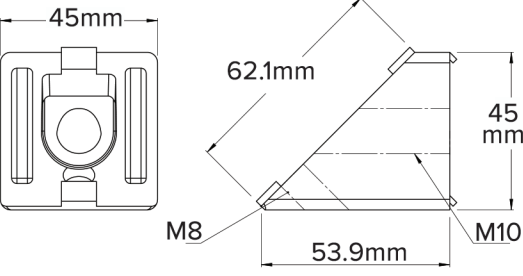
Weight (g) 350.0



45 X 45 45° Angle Connector
Connects 45mm profile at a 45° angle.

Part No. BCAA054045045045

Weight (g) 112.4

ANGLE CONNECTION BRACKETS

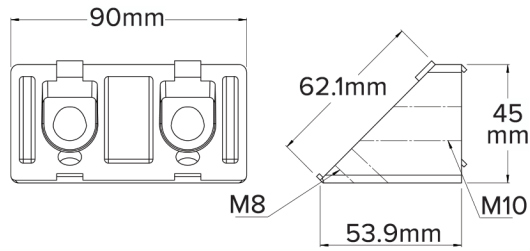
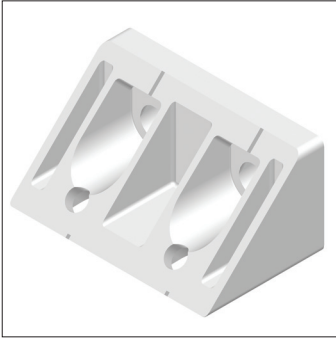

90 X 45 45° Angle Connector
Connects 45 x 90mm profile at a
45° angle.

Part No. BCAA054090045045

Weight (g) 216.2

CONNECTION PLATES

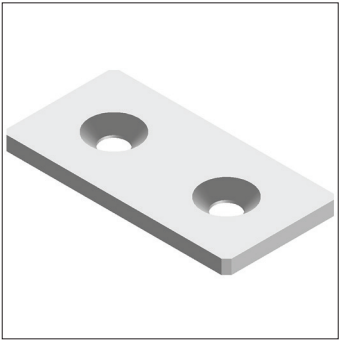
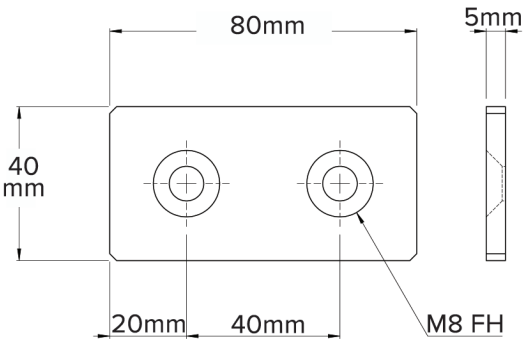
40 X 80 Connection Plate
Used to connect two 40mm aluminum profiles.

Part No. BCPS040080 **Weight (g)** 116.0

80 X 80 Connection Plate
Used to connect two 40mm aluminum profiles.

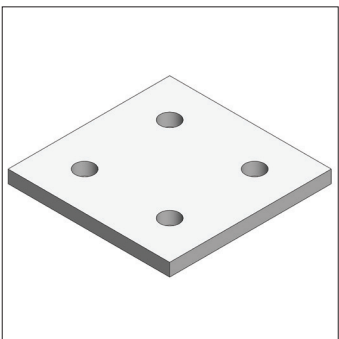
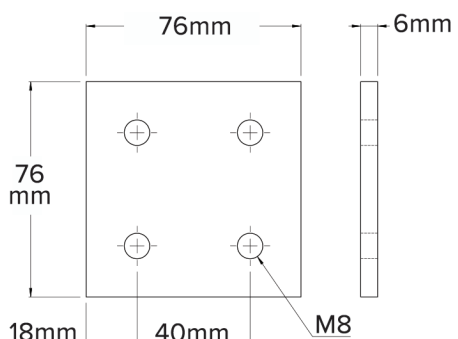
Part No. BCPA076076 **Weight (g)** 90.0

45 X 90 Connection Plate
Used to connect two 45mm aluminum profiles.

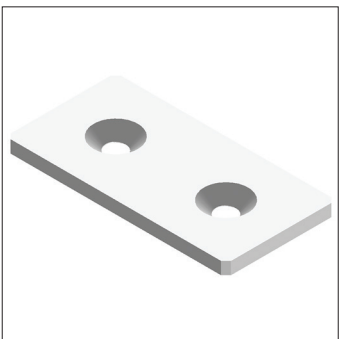
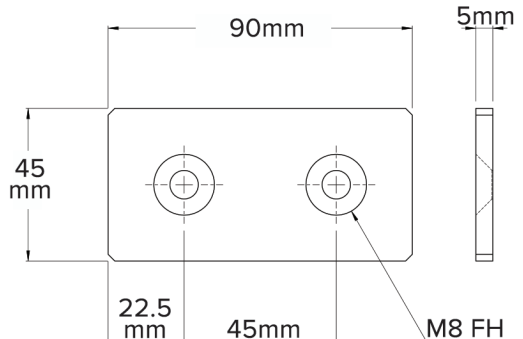
Part No. BCPS045090 **Weight (g)** 149.0

90 X 90 Connection Plate
Used to connect two 45mm aluminum profiles.

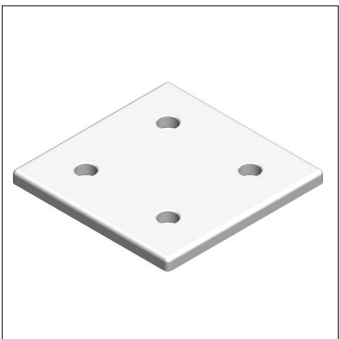
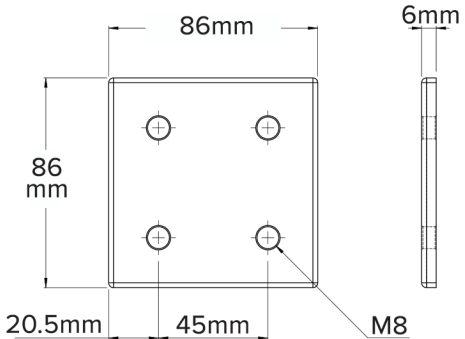
Part No. BCPA086086 **Weight (g)** 115.0

SWIVEL JOINTS

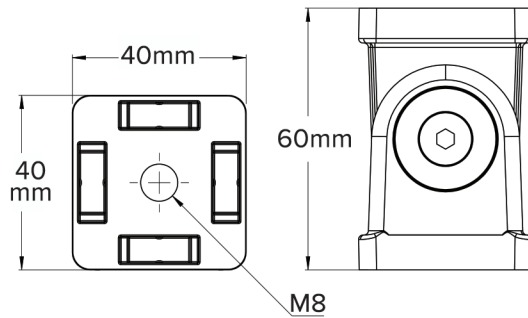
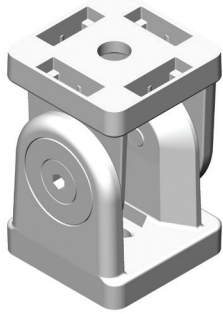

40 X 40 Pivot Joint

Used to connect 40mm aluminum profile with a pivoting joint using an allen wrench for adjustment.

Part No.

BPJA040040

Weight (g)

305.0

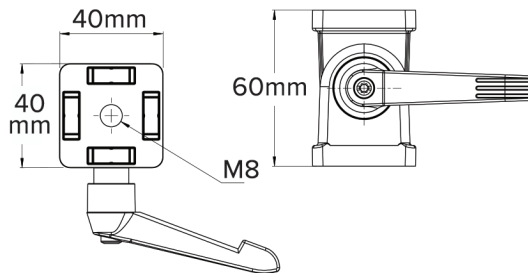
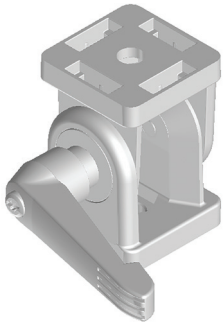

40 X 40 Pivot Joint w/ Locking Lever

Used to connect 40mm aluminum profile with a pivoting joint using a locking lever for adjustment.

Part No.

BLPJZ040040

Weight (g)

338.0

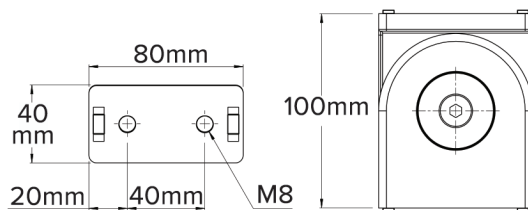
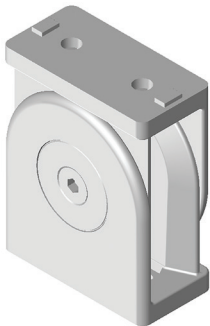

40 X 80 Pivot Joint

Used to connect 40 X 80mm aluminum profile with a pivoting joint using an allen wrench for adjustment.

Part No.

BPJZ040080

Weight (g)

997.0

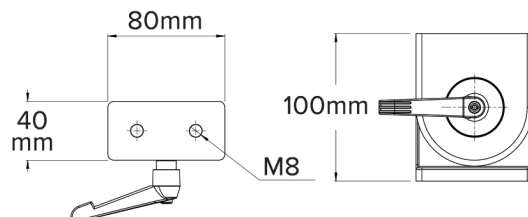
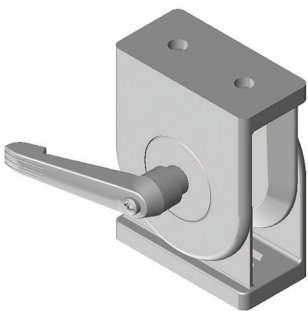

40 X 80 Pivot Joint w/ Locking Lever

Used to connect 40 X 80mm aluminum profile with a pivoting joint using a locking lever for adjustment.

Part No.

BLPJZ080040

Weight (g)

1120.0

SWIVEL JOINTS

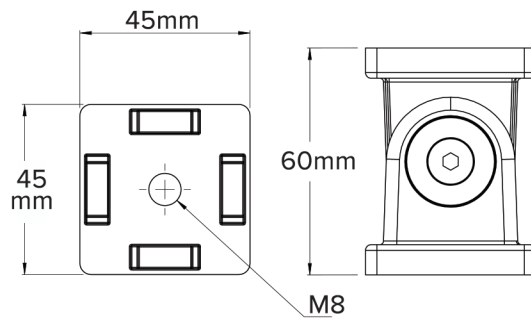
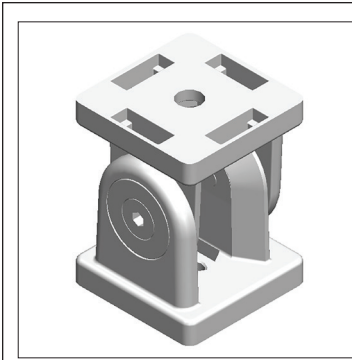

45 X 45 Pivot Joint

Used to connect 45mm aluminum profile with a pivoting joint using an allen wrench for adjustment.

Part No.

BPJA045045

Weight (g)

339.0

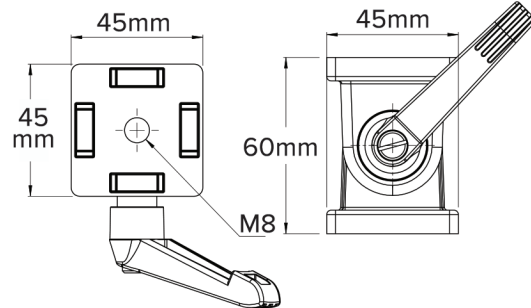
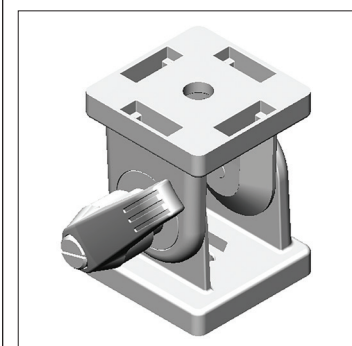

45 X 45 Pivot Joint w/ Locking Lever

Used to connect 45mm aluminum profile with a pivoting joint using a locking lever for adjustment.

Part No.

BLPJZ045045

Weight (g)

387.0

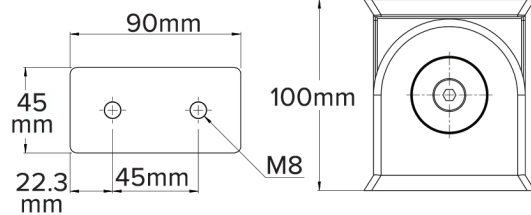
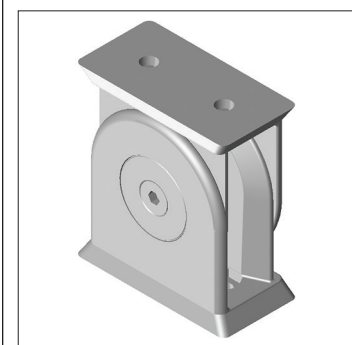

45 X 90 Pivot Joint

Used to connect 45mm aluminum profile with a pivoting joint using an allen wrench for adjustment.

Part No.

BPJA045090

Weight (g)

1046.0

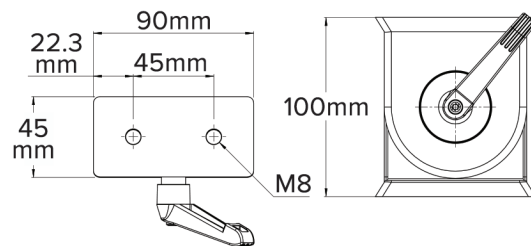
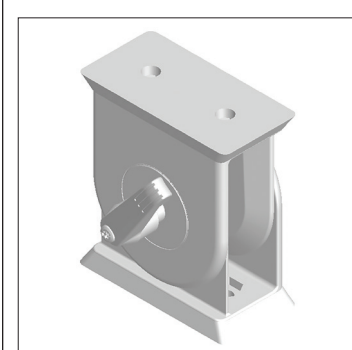

45 X 90 Pivot Joint w/ Locking Lever

Used to connect 45 x 90mm aluminum profile with a pivoting joint using a locking lever for adjustment.

Part No.

BLPJZ045090

Weight (g)

1069.0

BRACKETS

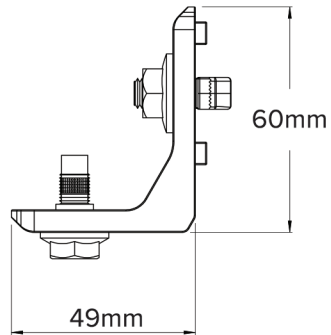
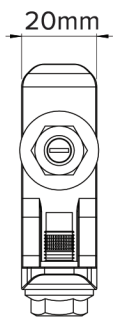
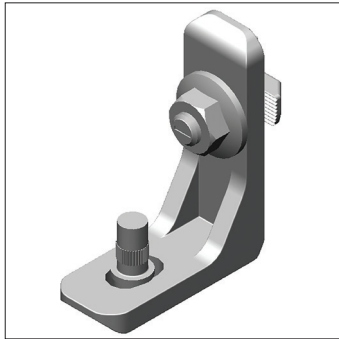

20mm 60 X 49 Suspension Bracket

Used to connect frames to a post.
4 per package.

Part No.

BSBZ060020049

Weight (g)

106.0

CONNECTORS

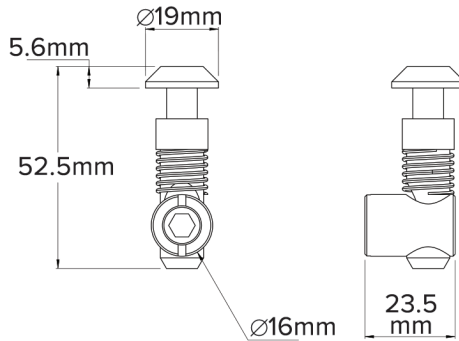
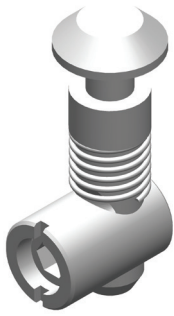

40mm Connector

Used to connect two 40mm aluminum profiles in a right angle.

Part No. CFUCS525019023

Weight (g) 65.0

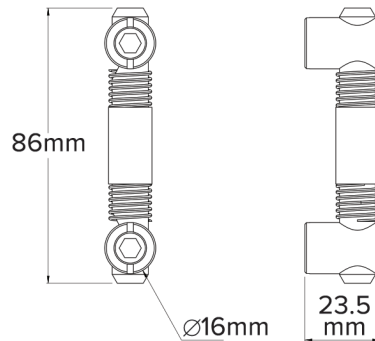
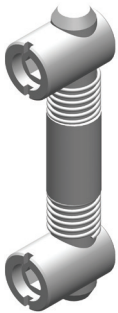

40mm Longitudinal Connector

Used to connect two 40mm aluminum profiles end to end.

Part No. CFDCS086019023

Weight (g) 115.1

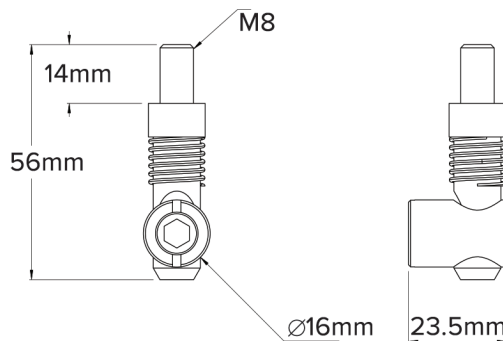
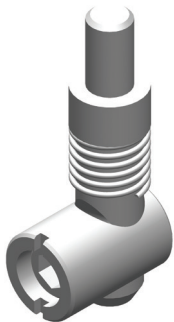

40mm Threaded Connector

Used to connect aluminum profile to flat plates.

Part No. CFTCS056016023M08

Weight (g) 60.6

FASTENERS

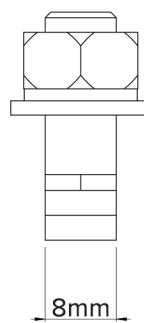
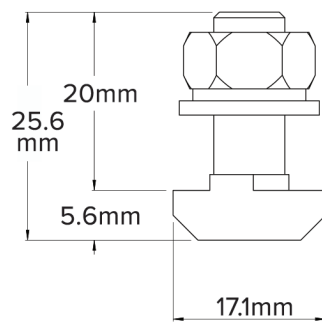

M8 X 20mm Hammer Head

Used to fasten components to aluminum profiles.

Part No.

CFHHS020M8

Weight (g)

18.7

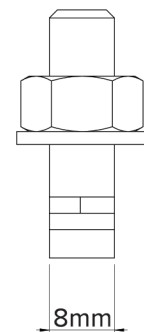
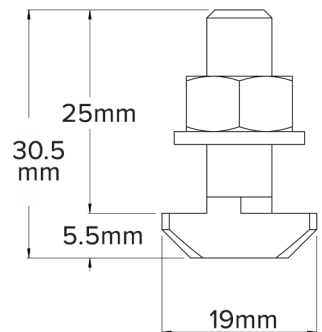
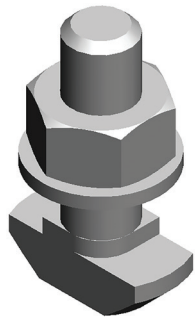

M8 X 25mm Hammer Head

Used to fasten components to aluminum profiles.

Part No.

CFHHS025M8

Weight (g)

20.2

THREADED INSERTS

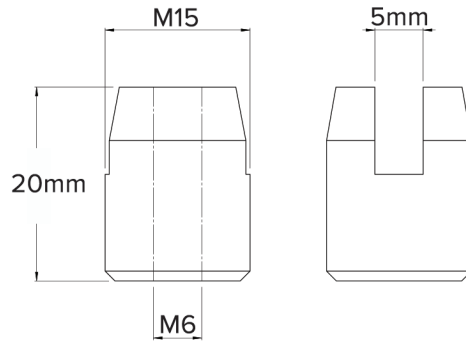
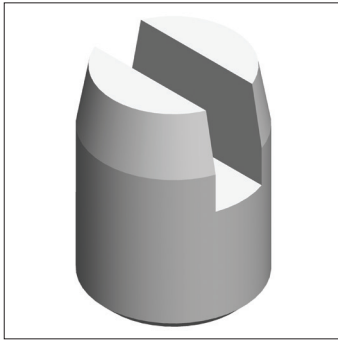

M6 Threaded Insert

Used to fasten components to aluminum profiles.

Part No.

CFIS020M15M06

Weight (g)

16.0

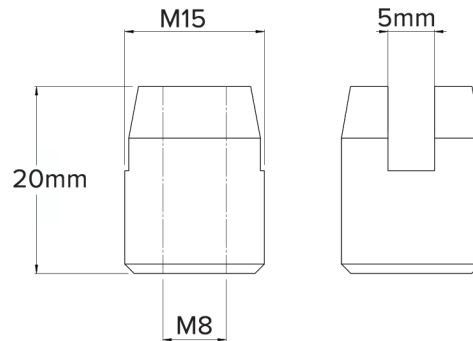
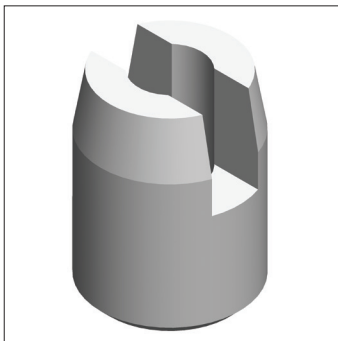

M8 Threaded Insert

Used to fasten components to aluminum profiles.

Part No.

CFIS020M15M08

Weight (g)

15.0

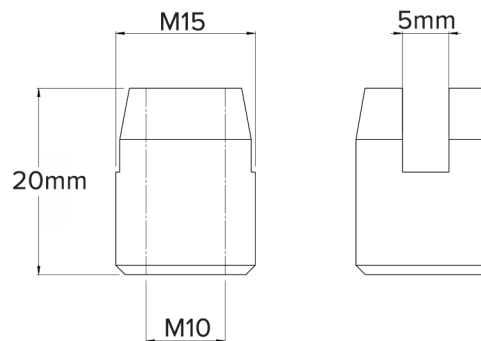
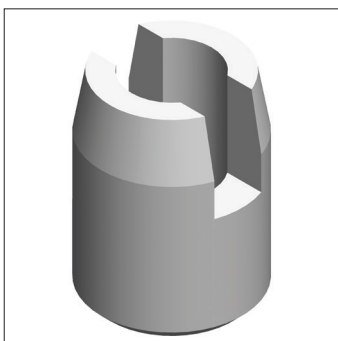

M10 Threaded Insert

Used to fasten components to aluminum profiles.

Part No.

CFIS020M15M10

Weight (g)

15.0

FASTENING ELEMENTS

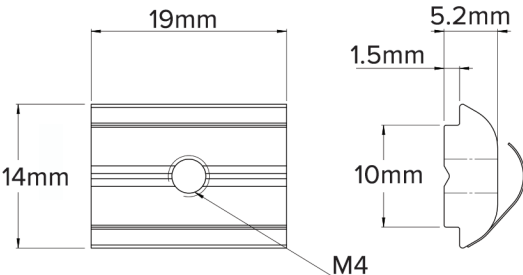
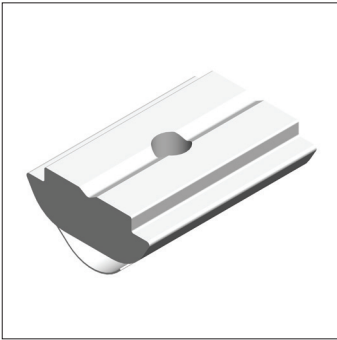

**M4 Roll-In Spring Leaf
T-Nut Slot 10**
Used to fasten components to aluminum profiles using a screw.

Part No.	Weight (g)
CFSLS019010M4	7.7

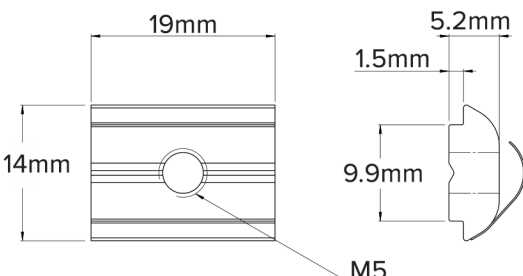
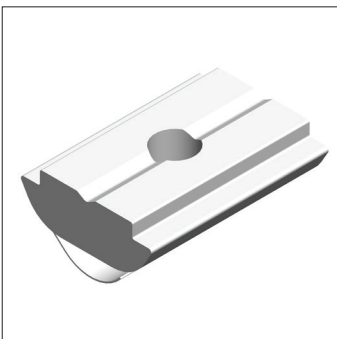

**M5 Roll-In Spring Leaf
T-Nut Slot 10**
Used to fasten components to aluminum profiles using a screw.

Part No.	Weight (g)
CFSLS019010M5	7.6

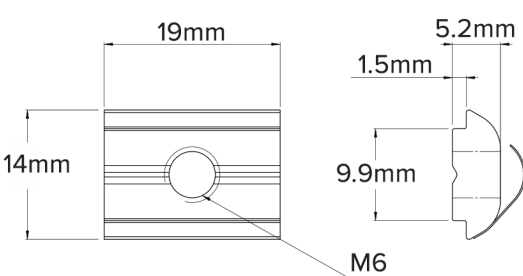
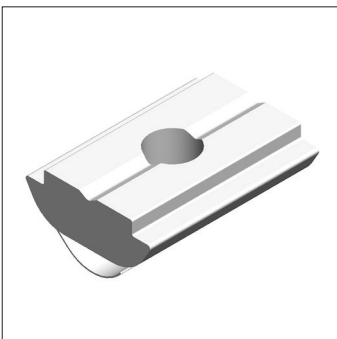

**M6 Roll-In Spring Leaf
T-Nut Slot 10**
Used to fasten components to aluminum profiles using a screw.

Part No.	Weight (g)
CFSLS019010M6	7.4

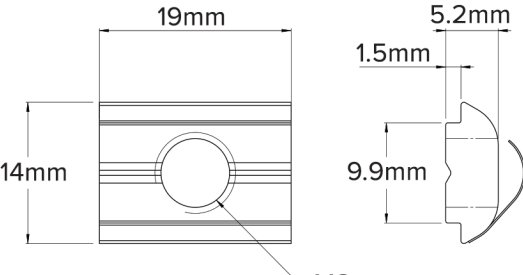
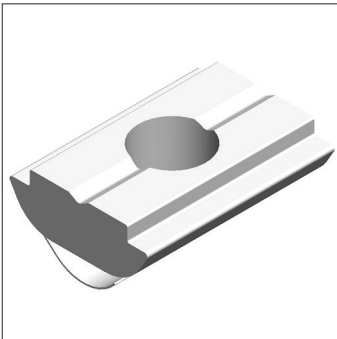

**M8 Roll-In Spring Leaf
T-Nut Slot 10**
Used to fasten components to aluminum profiles using a screw.

Part No.	Weight (g)
CFSLS019010M8	7.1

FASTENING ELEMENTS

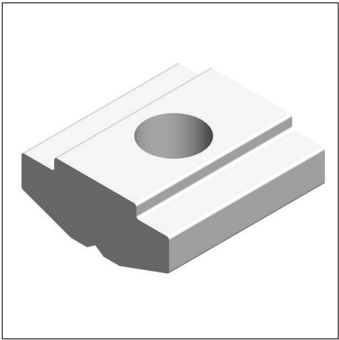
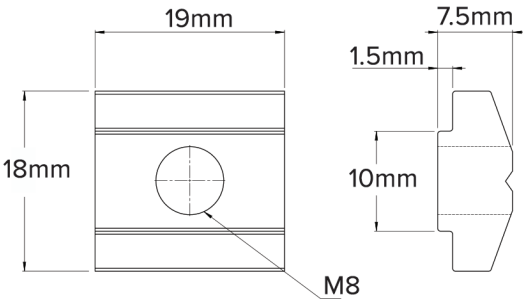
M8 X 1.25 Hi-Torque T-Nut
Fasten high torque components to aluminum profiles using a screw.

Part No. CFHTS019010M08

Weight (g) 14.1

M8 Threaded Key Nut Slot 10
Extended t-nut to facilitate keying a plate to an extrusion.

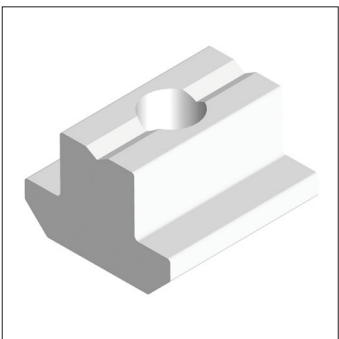
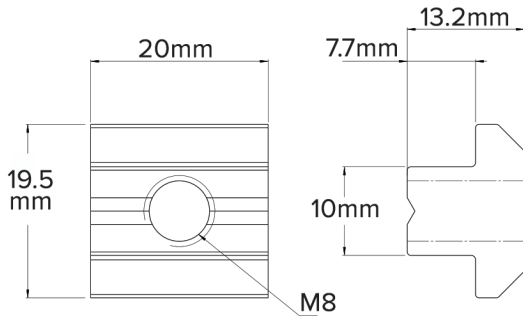
Part No. CFKNS020010M08

Weight (g) 23.4

M8 Threaded 200mm Splice Nut
Fasten large components to aluminum profiles using a screw.

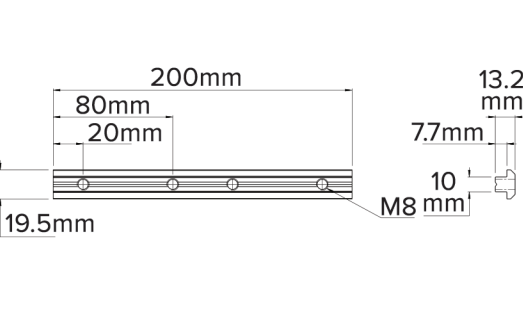
Part No. CFSNS200010M08

Weight (g) 256.0



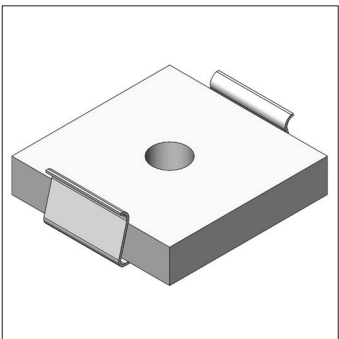
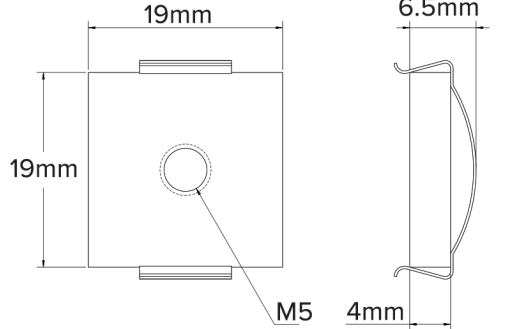

M5 Insert Nut
Fasten components to aluminum profiles using a screw.

Part No. CFTPS019019004M05

Weight (g) 10.2

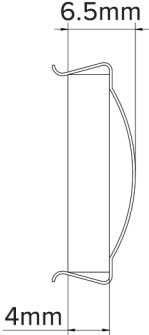
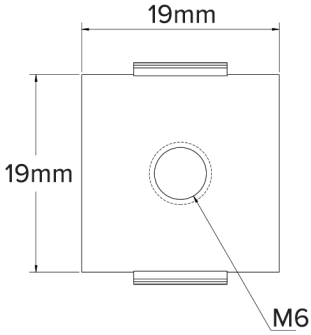
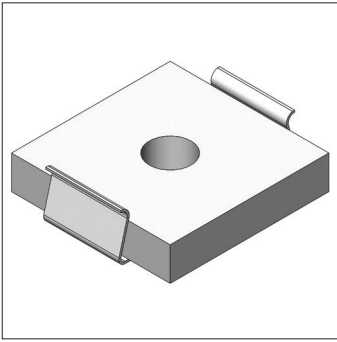
FASTENING ELEMENTS



M6 Insert Nut
Fasten components to aluminum profiles using a screw.

Part No. CFTPS019019004M06

Weight (g) 9.8

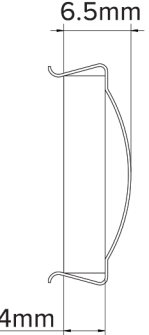
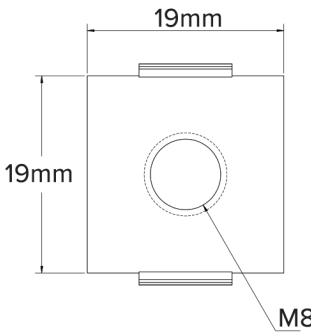
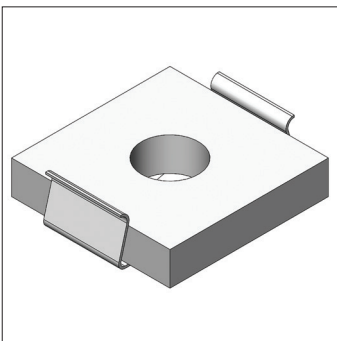

M8 Insert Nut
Fasten components to aluminum profiles using a screw.

Part No. CFTPS019019004M08

Weight (g) 9.1

FEET

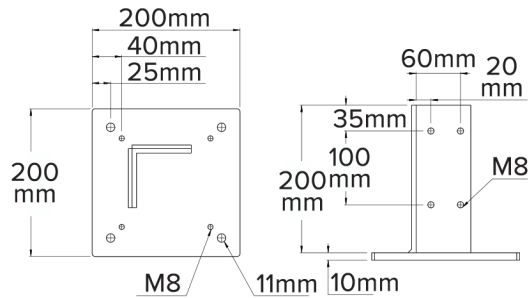
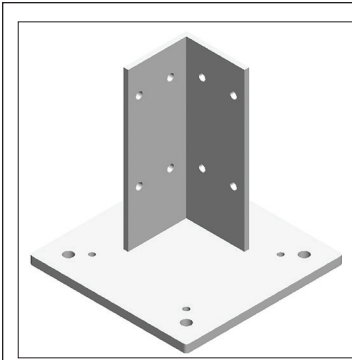

200mm Floor Mount Foot

Used for leveling and floor mounting
80mm aluminum profile.

Part No. FBFS200200210M08

Weight (g) 4209.3

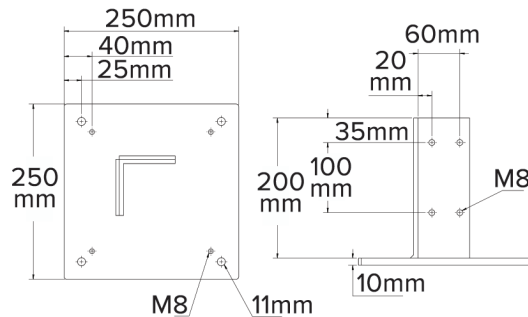
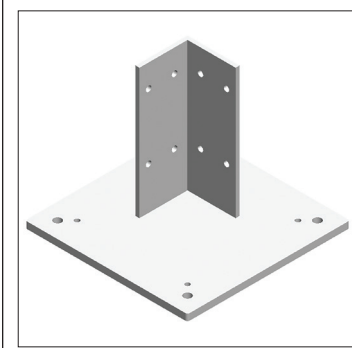

250mm Floor Mount Foot

Used for leveling and floor mounting
80mm aluminum profile.

Part No. FBFS250250210M08

Weight (g) 5846.8

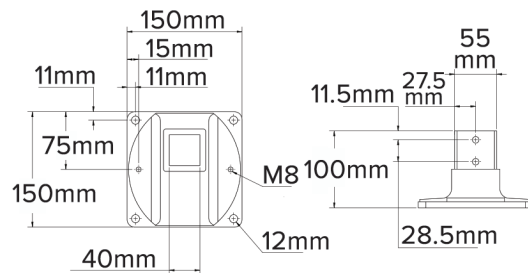
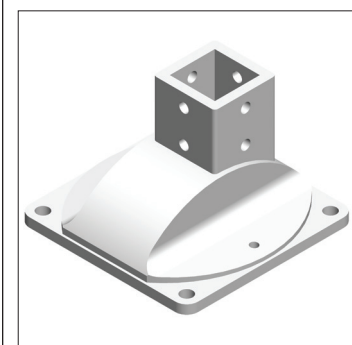

40mm Floor Mount Base

Post mounts 40 x 40mm extrusion.

Part No. FBF40150150100

Weight (g) 940.0

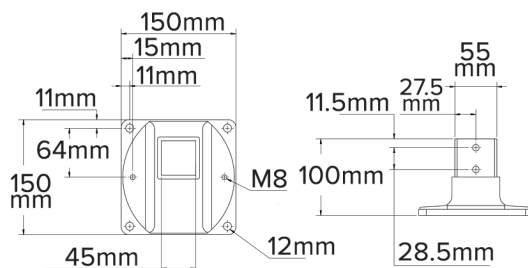
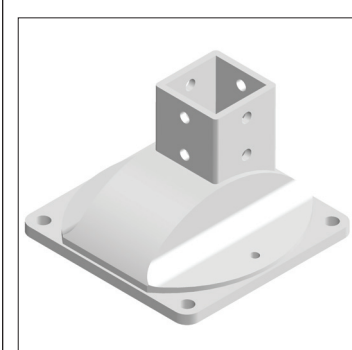

45mm Floor Mount Base

Post mounts 45 x 45mm extrusion.

Part No. FBF45150150100

Weight (g) 820.0

FEET

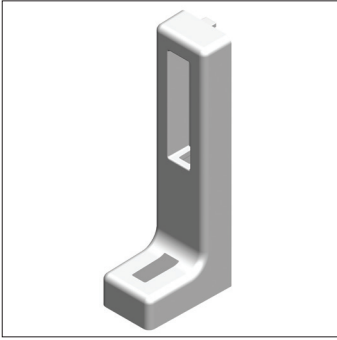
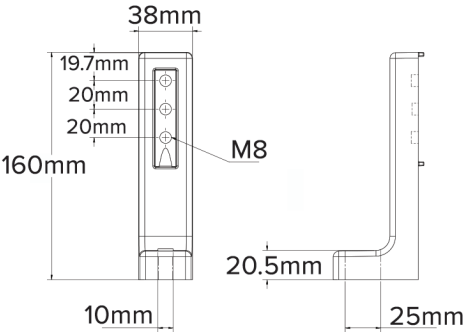
160mm Adjusting Foot w/out Screw
Levels and lags floor mounted walls.

Part No. FAFZ160038060

Weight (g) 110.0

160mm Adjusting Foot w/ Screw
Levels and lags floor mounted walls and includes an adjustment screw.

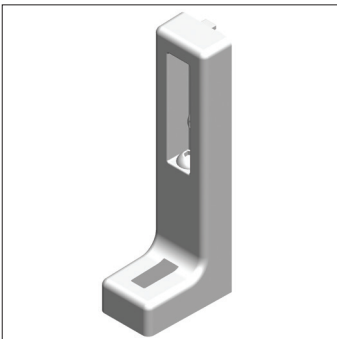
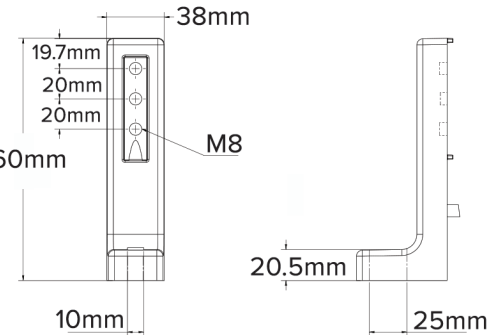
Part No. FAFSZ160038060

Weight (g) 505.0

Base Angle Foot
Levels and lags to the floor.

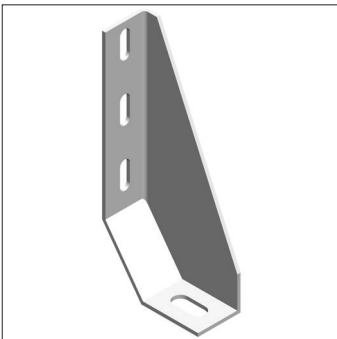
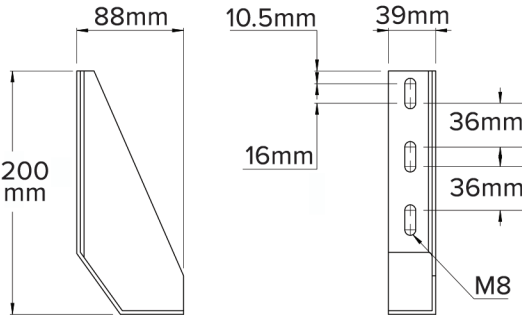
Part No. FBFS088039200M08

Weight (g) 456.0



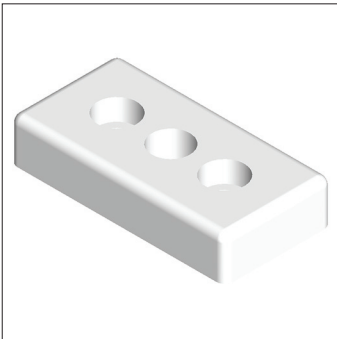
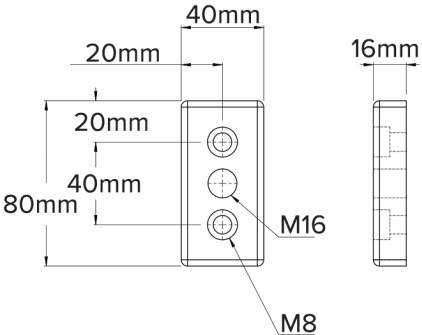

M16 40 X 80 Base Plate
Attaches leveling feet, casters, hooks, or similar components to the 40 x 80mm series aluminum profile.

Part No. FBPZ040080016M16

Weight (g) 199.0

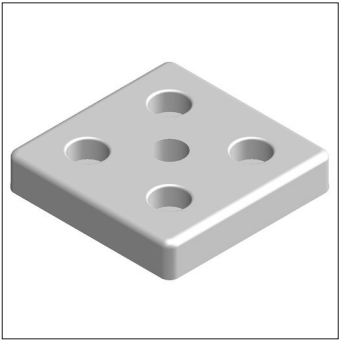
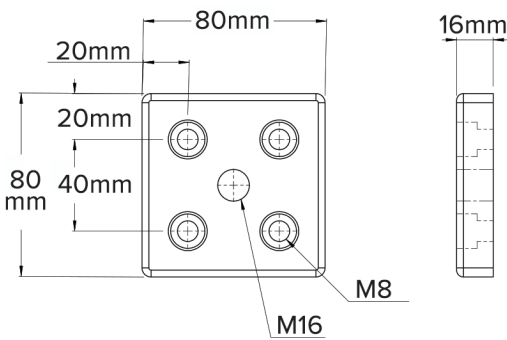
FEET

M16 80 X 80 Base Plate
Attaches leveling feet, casters, hooks, or similar components to the 80 x 80mm series aluminum profile.

Part No. FBPZ080080016M16

Weight (g) 357.7

M16 45 X 90 Base Plate
Attaches leveling feet, casters, hooks, or similar components to the 45 x 90mm series aluminum profile.

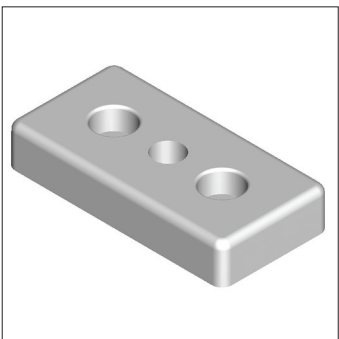
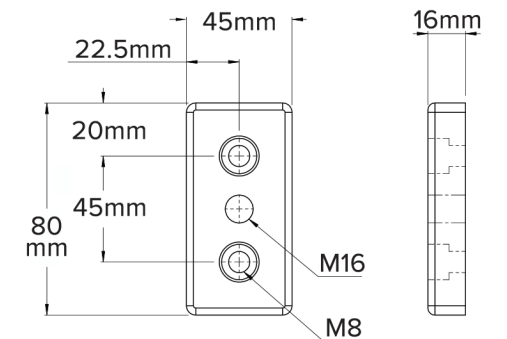
Part No. FBPZ045090016M16

Weight (g) 266.0

M16 90 X 90 Base Plate
Attaches leveling feet, casters, hooks, or similar components to the 90 x 90mm series aluminum profile.

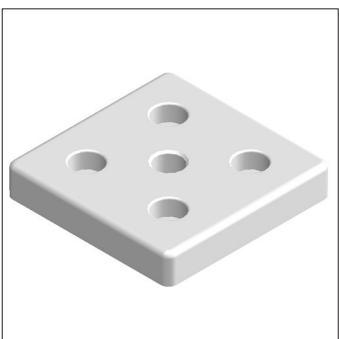
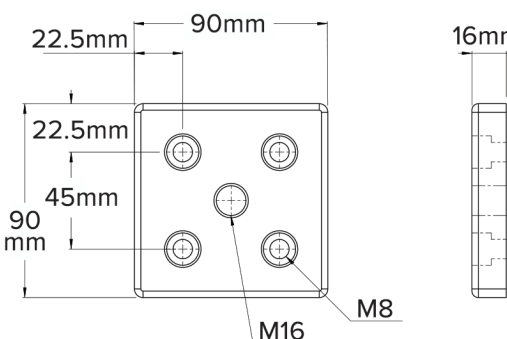
Part No. FBPZ090090016M16

Weight (g) 516.0



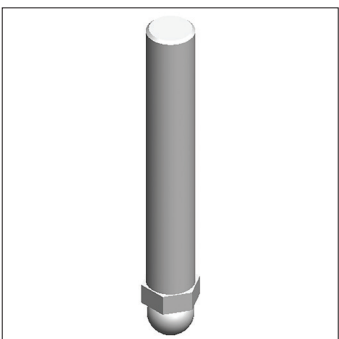
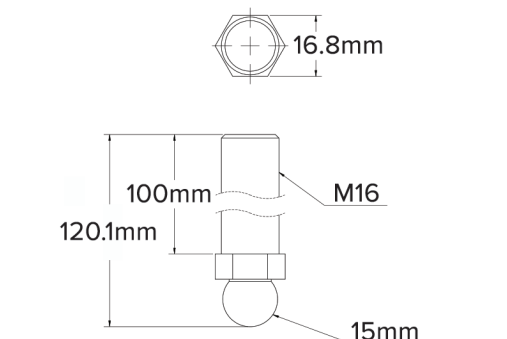

15mm Ball Threaded Rod for Swivel Feet
100mm M16 threaded rod w/ 15mm ball used for leveling w/ a swivel foot.

Part No. FTRS100M16

Weight (g) 156.0

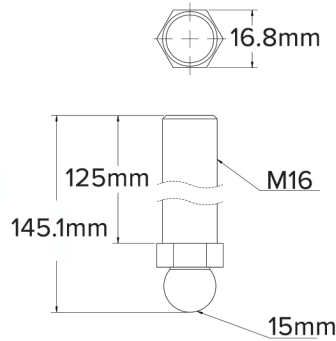
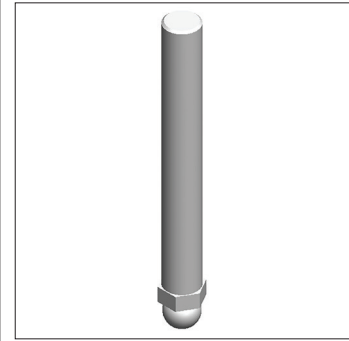
FEET



15mm Ball Threaded Rod for Swivel Feet

125mm M16 threaded rod w/ 15mm ball used for leveling w/ a swivel foot.

Part No. FTRS125M16

Weight (g) 190.0

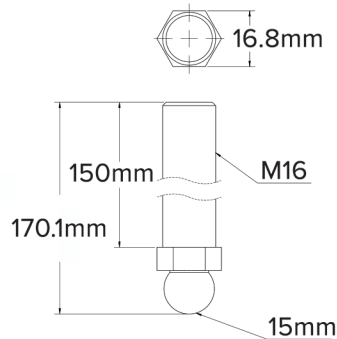
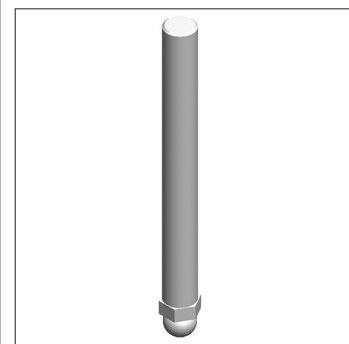

15mm Ball Threaded Rod for Swivel Feet

150mm M16 threaded rod w/ 15mm ball used for leveling w/ a swivel foot.

Part No. FTRS150M16

Weight (g) 222.0

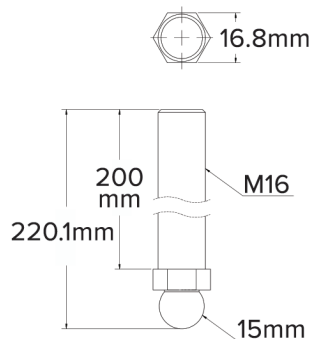
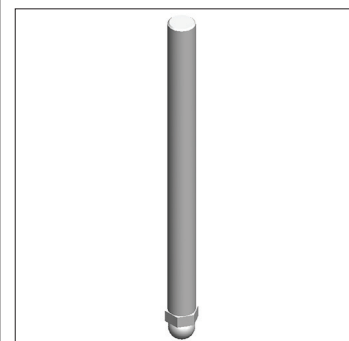

15mm Ball Threaded Rod for Swivel Feet

200mm M16 threaded rod w/ 15mm ball used for leveling w/ a swivel foot.

Part No. FTRS200M16

Weight (g) 285.0

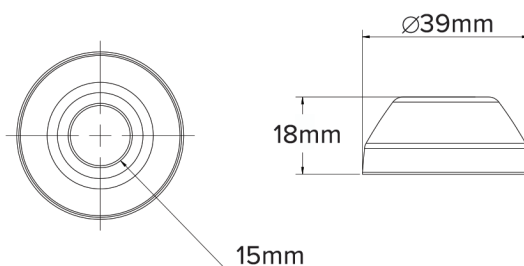
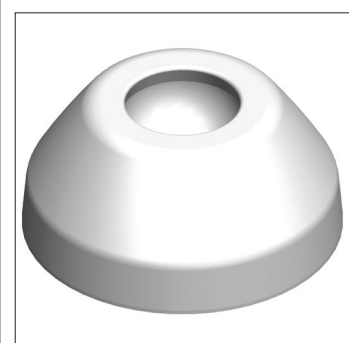

40mm Plastic Swivel Foot

Swiveling leveling foot w/ 15mm ball socket.

Part No. FPSP039018

Weight (g) 13.0

FEET

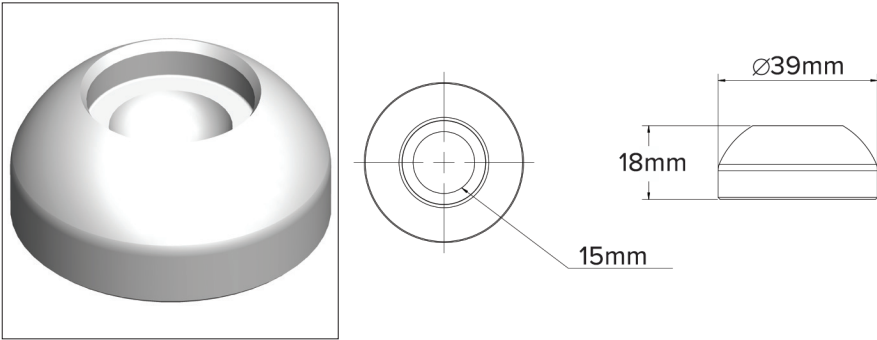

40mm Steel Swivel Foot
Swiveling leveling foot w/ 15mm ball socket.

Part No. FPSS039018

Weight (g) 99.0

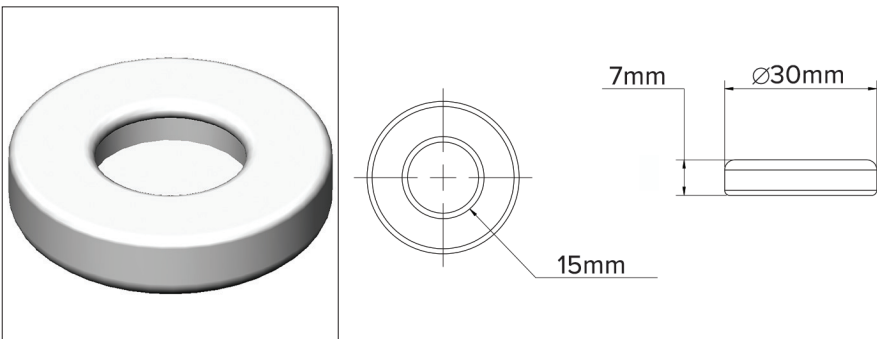

Anti-Slip Pad for 40mm Swivel Foot
Prevents slippage and absorbs vibration.

Part No. FASR030007

Weight (g) 4.0

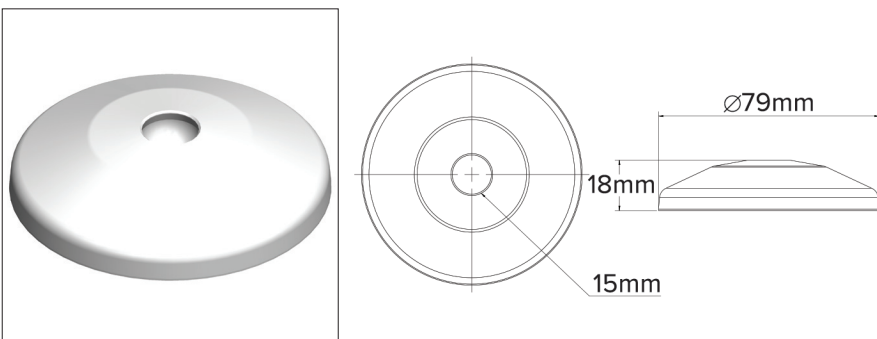

80mm Plastic Swivel Foot
Swiveling leveling foot w/ 15mm ball socket.

Part No. FPSP079018

Weight (g) 44.0

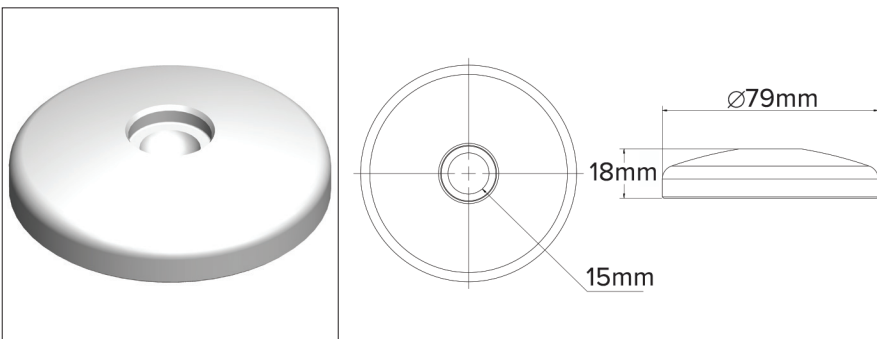

80mm Steel Swivel Foot
Swiveling leveling foot w/ 15mm ball socket.

Part No. FPSS079018

Weight (g) 380.0

FEET

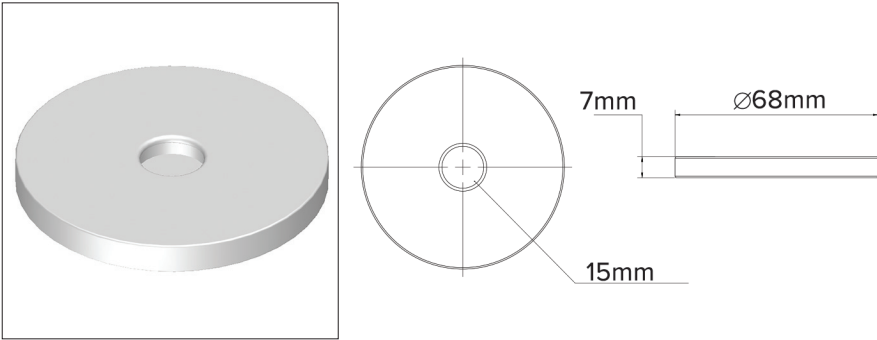

Anti-Slip Pad for 80mm Swivel Foot
Prevents slippage and absorbs vibration.

Part No. FASR068007

Weight (g) 23.0

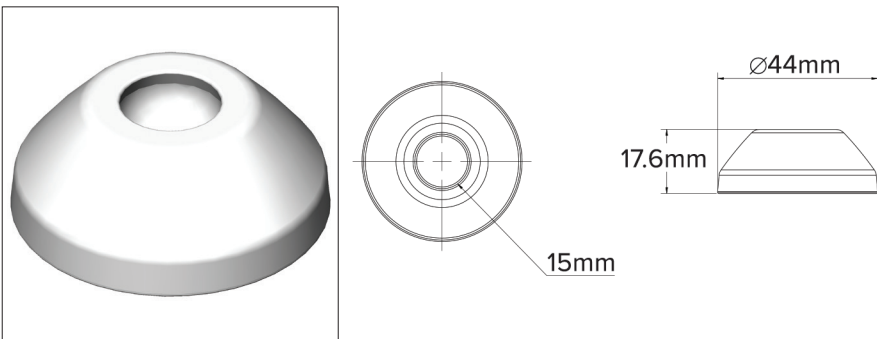

45mm Plastic Swivel Foot
Swiveling leveling foot w/ 15mm ball socket.

Part No. FPSP044018

Weight (g) 15.0

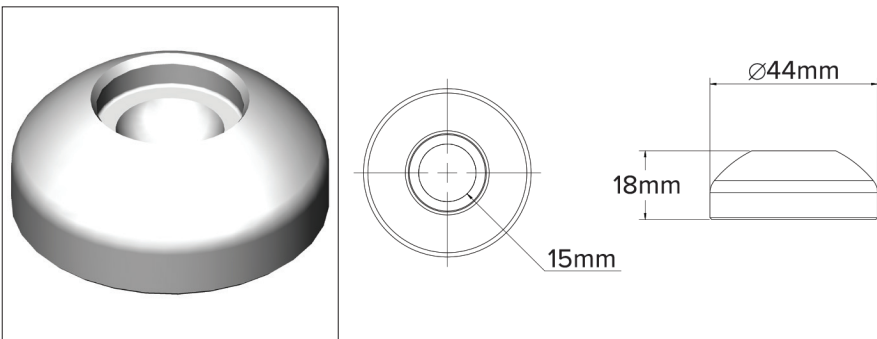

45mm Steel Swivel Foot
Swiveling leveling foot w/ 15mm ball socket.

Part No. FPSS044018

Weight (g) 123.0

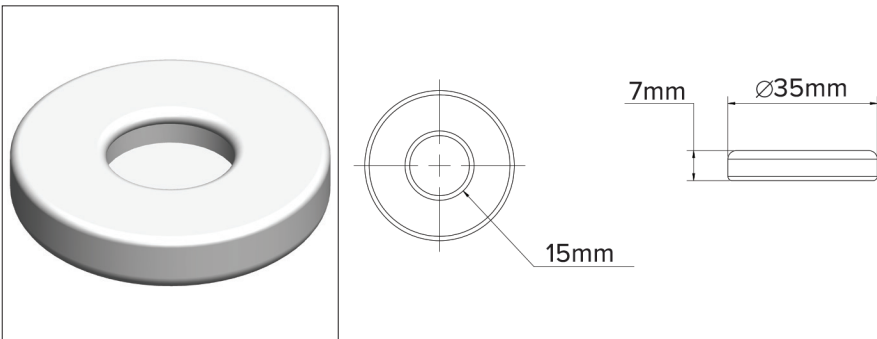

Anti-Slip Pad for 45mm Swivel Foot
Prevents slippage and absorbs vibration.

Part No. FASR035007

Weight (g) 6.0

FEET

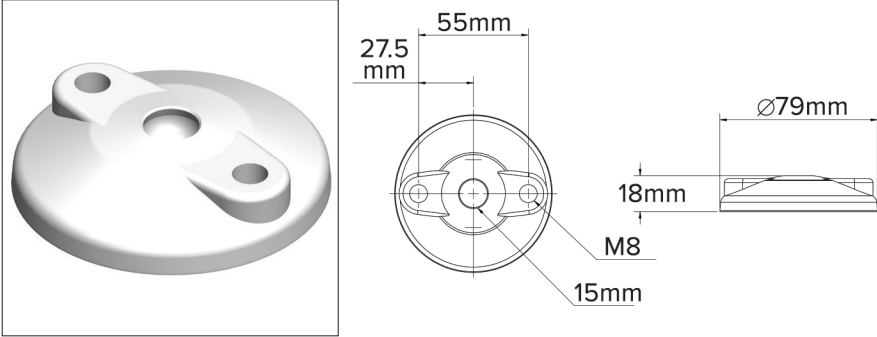

80mm Plastic Swivel Foot w/ M8 Holes
Leveling swivel foot w/ M8 bolt down holes.

Part No. FPSHP079018

Weight (g) 46.0

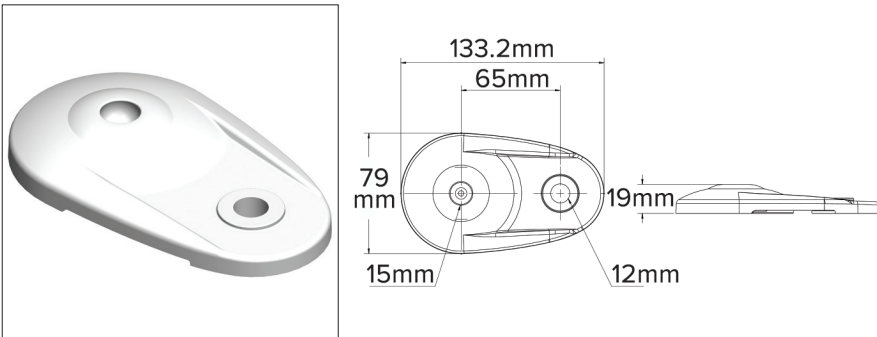

80mm Plastic Teardrop Swivel Foot
Leveling swivel foot w/ 12mm lag hole.

Part No. FPSTP133079019

Weight (g) 58.8

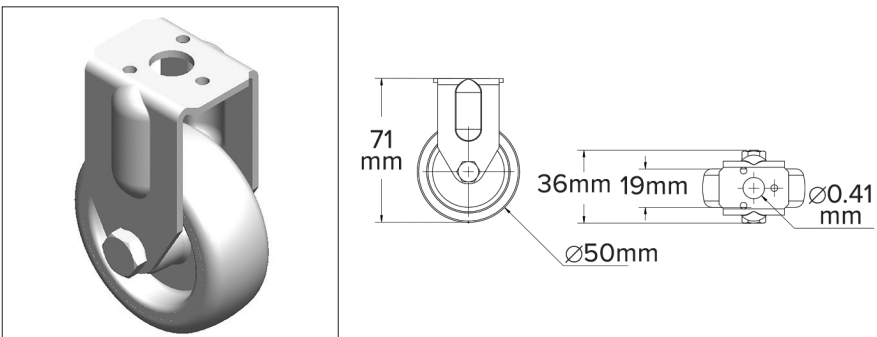

50mm Polyurethane Caster
Thermoplastic rigid caster capable of supporting 165 lbs.

Part No. FRCAPU019050

Weight (g) 130.0

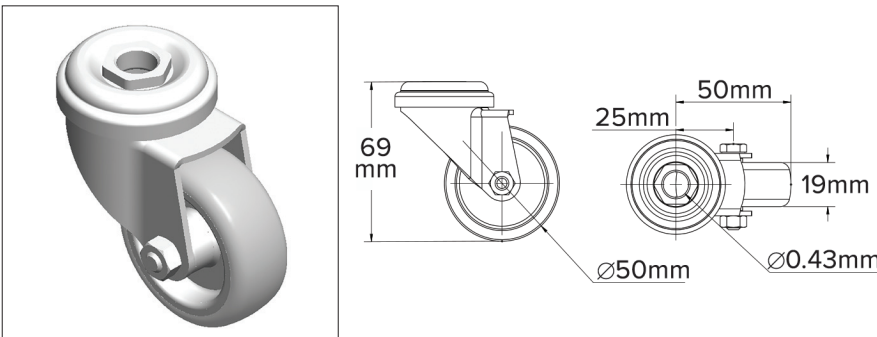

50mm Polyurethane Swivel Caster
Thermoplastic swivel caster capable of supporting 165 lbs.

Part No. FSCAPU019050

Weight (g) 180.0

FEET

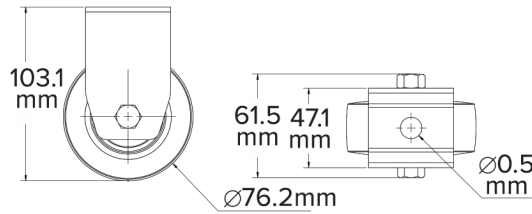

75mm Rigid Rubber Caster
Thermoplastic rigid caster capable of supporting 210 lbs.

Part No. FRCATR032075

Weight (g) 240.0

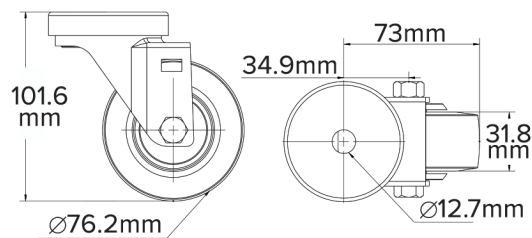
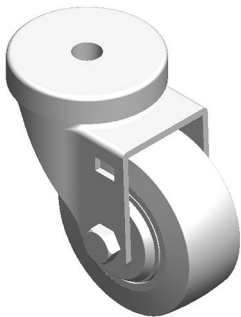

75mm Rubber Swivel Caster
Thermoplastic swivel caster capable of supporting 210lbs.

Part No. FSCATR032075

Weight (g) 310.0

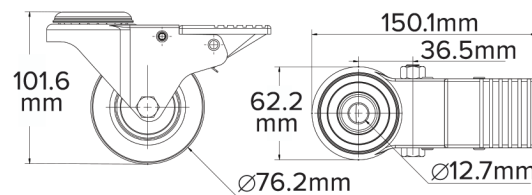
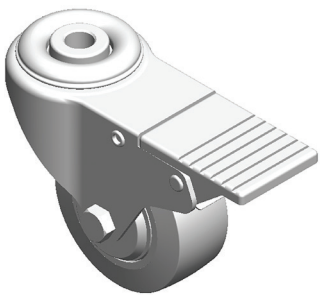

75mm Rubber Swivel Caster w/ Brake
Thermoplastic caster w/ total lock brake capable of supporting 210lbs.

Part No. FSLCATR032075

Weight (g) 450.0

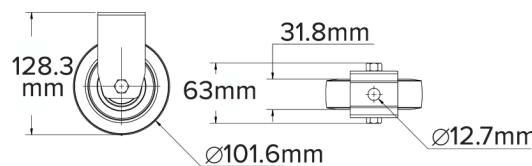

100mm Rubber Rigid Caster
Thermoplastic caster capable of supporting 250lbs.

Part No. FRCATR032100

Weight (g) 680.0

FEET

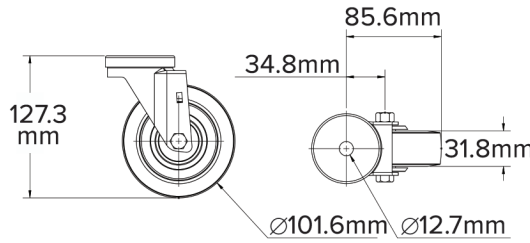
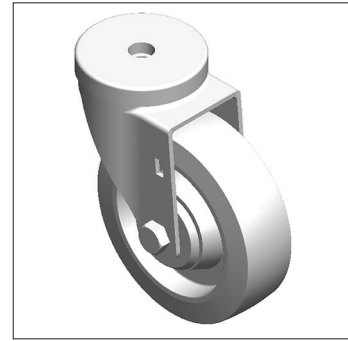

100mm Rubber Swivel Caster

Thermoplastic caster capable of supporting 250lbs.

Part No. FSCATR032100

Weight (g) 500.0

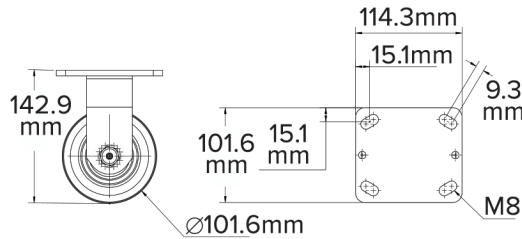
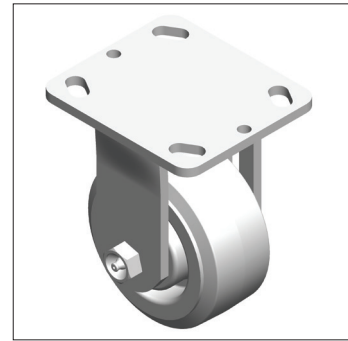

100mm 3/8" Rubber Rigid Caster

Thermoplastic caster capable of supporting 260 lbs.

Part No. FRCATR100

Weight (g) 1814.0

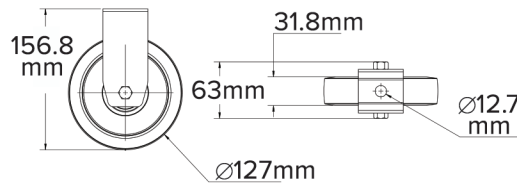

125mm Rubber Rigid Caster

Thermoplastic caster capable of supporting 260lbs.

Part No. FRCATR032125

Weight (g) 900.0

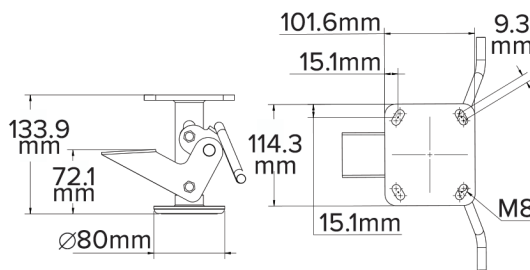

4" Floor Lock Lift

Raises equipment off casters. Extends 101.6mm from listed dimension.

Part No. FLLS0450046

Weight (g) 450.0

PANELS

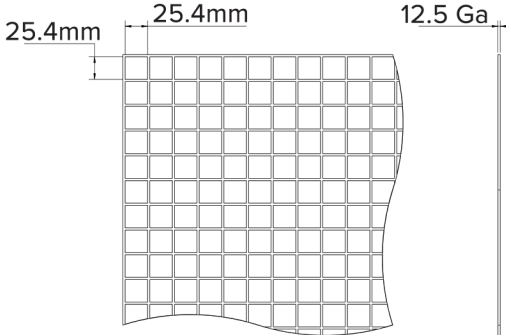
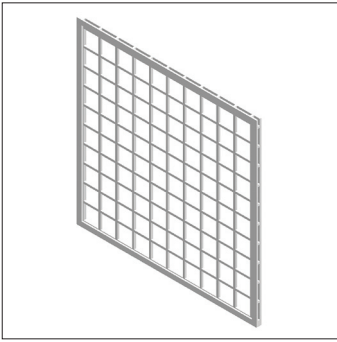

12.5Ga 1" Sq. PVC Coated Black Wire Mesh
Fill panels when using aluminum profile.

Part No. PWMS096048001

Weight (g/cm²) 0.34

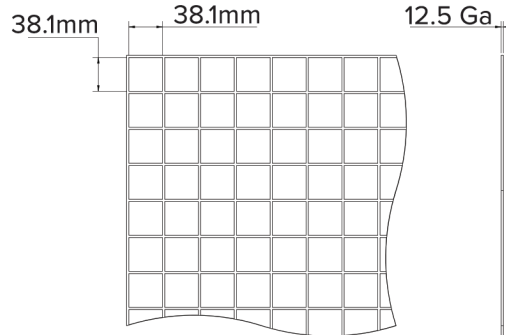
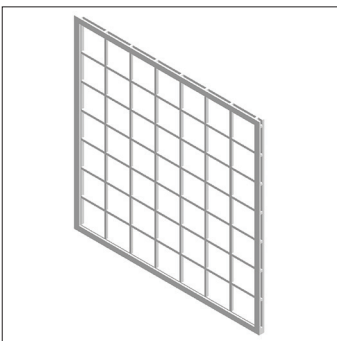

12.5Ga 1.5" Sq. PVC Coated Black Wire Mesh
Fill panels when using aluminum profile.

Part No. PWMS096048015

Weight (g/cm²) 0.24

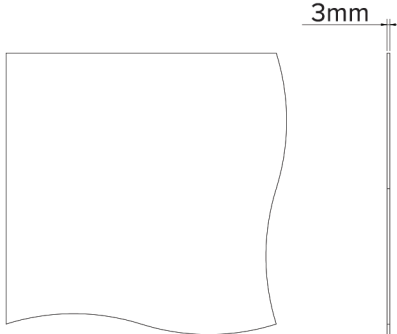
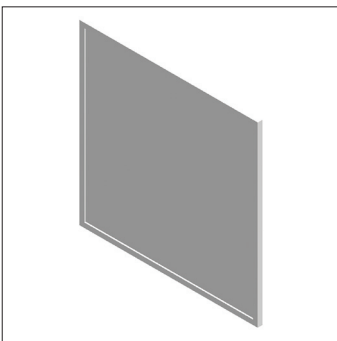

4' X 8' 3mm Silver Metallic Signabond
Fill panels when using aluminum profile.

Part No. PSGA096048003

Weight (g/cm²) 0.47

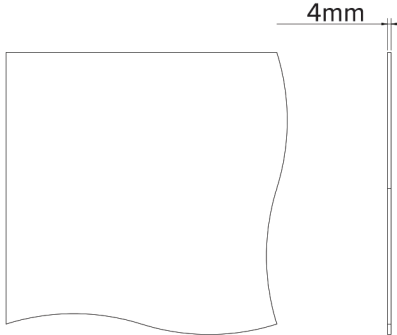
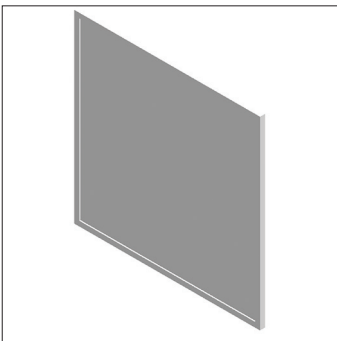



4' X 8' 4mm Poly-Carb
Fill panels when using aluminum profile.

Part No. PCPPC096048004

Weight (g/cm²) 0.47

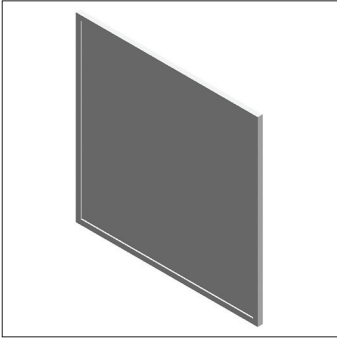
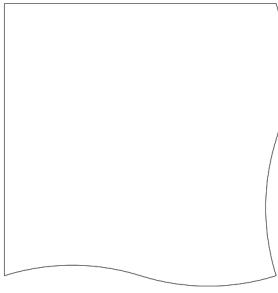
PANELS

4' X 8' 3mm Smoked Polycarbonate Panel
 Fill panels when using aluminum profile.

Part No. PSPPC096048003

Weight (g/cm²) 0.36

4' X 8' 6mm White Sintra
 Fill panels when using aluminum profile.

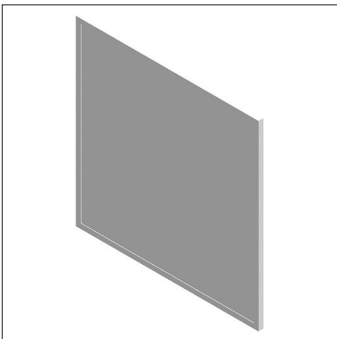
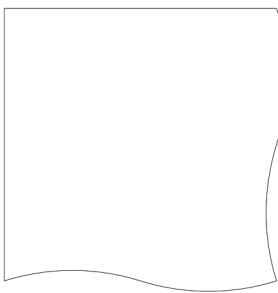
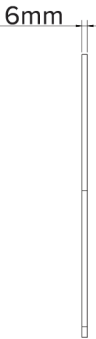
Part No. PPWS096048006

Weight (g/cm²) 0.43

4' X 8' 6mm Black Sintra
 Fill panels when using aluminum profile.

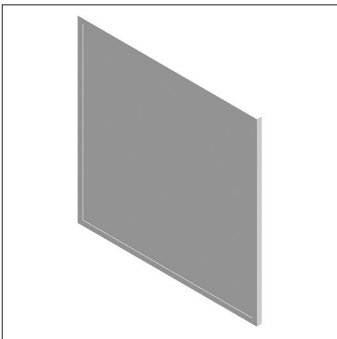
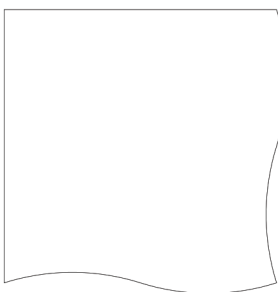
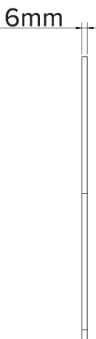
Part No. PPBS096048006

Weight (g/cm²) 0.43



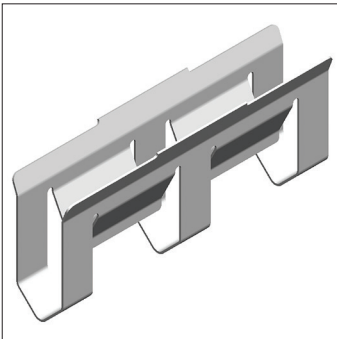
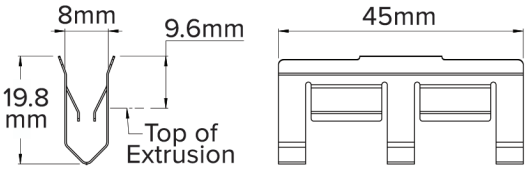

Spring Clip
 Secures panels in wire mesh profiles.

Part No. PSCS020010

Weight (g) 3.0

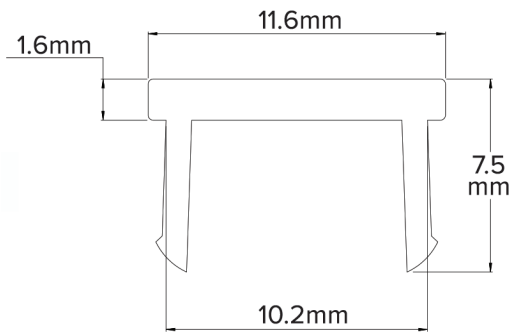
PANELS



Gray Slot Cover

Fills slots on aluminum extrusion.

Part No. PSCGP02M010075

Weight (g/m) 28.1

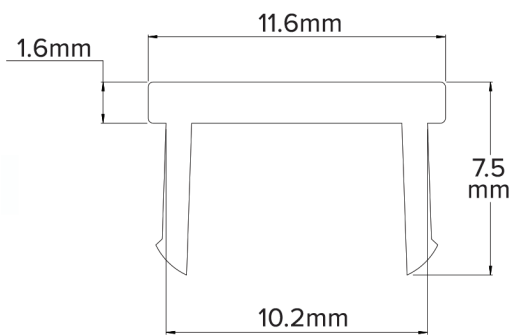

Yellow Slot Cover

Fills slots on aluminum extrusion.

Part No. PSCYP02M010075

Weight (g/m) 28.1

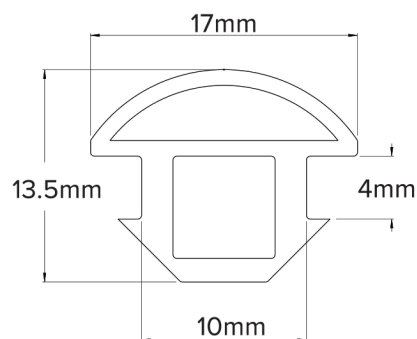
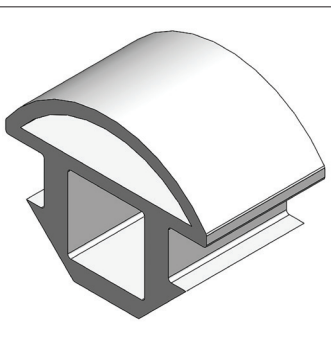

Door Seal

Seals doors when using aluminum profile.

Part No. PDSR075010

Weight (g/m) 94.6

ELECTRICAL ACCESSORIES

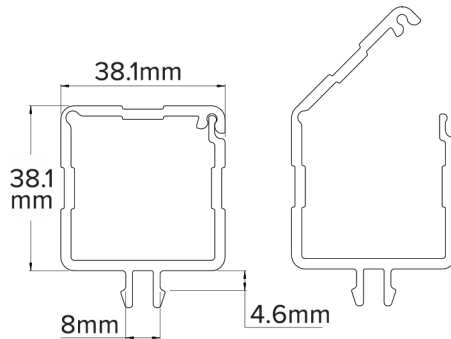
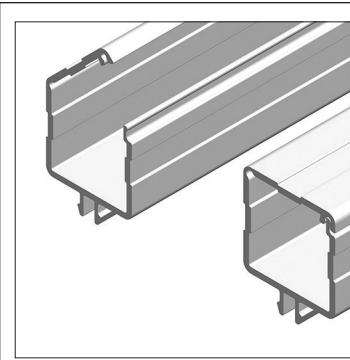

40 X 40 Gray Wire Way for 8mm Slot

Runs wires and cable on aluminum extrusion w/ an 8mm slot.

Part No. PWGP008040040008

Weight (g/m) 477.0

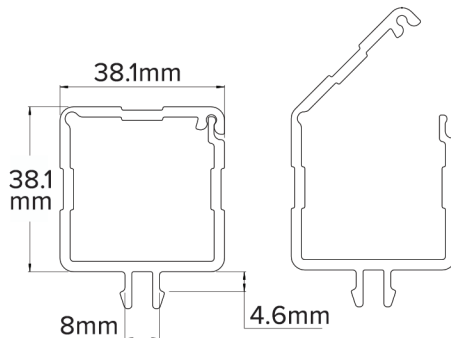
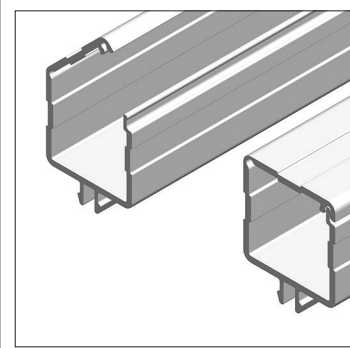

40 X 40 Black Wire Way for 8mm Slot

Runs wires and cable on aluminum extrusion w/ an 8mm slot.

Part No. PWBP008040040008

Weight (g/m) 477.0

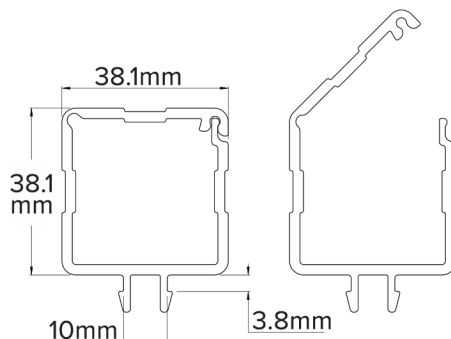
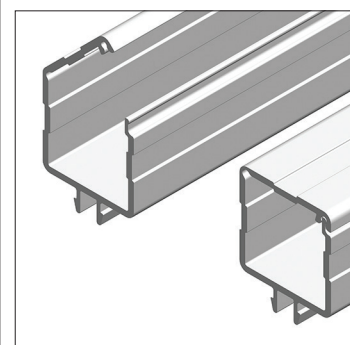

40 X 40 Gray Wire Way for 10mm Slot

Runs wires and cable on aluminum extrusion w/ a 10mm slot.

Part No. PWGP008040040010

Weight (g/m) 478.0

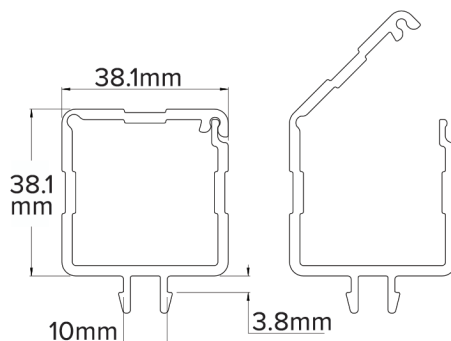
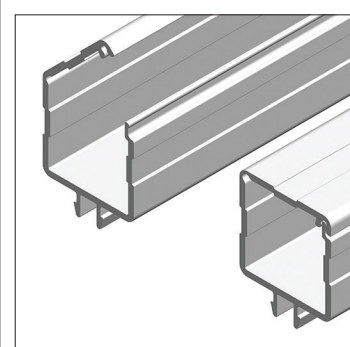

40 X 40 Black Wire Way for 10mm Slot

Runs wires and cable on aluminum extrusion w/ a 10mm slot.

Part No. PWBP008040040010

Weight (g/m) 478.0

ELECTRICAL ACCESSORIES

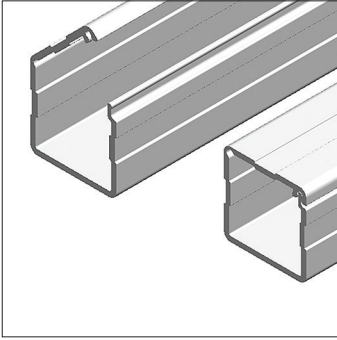
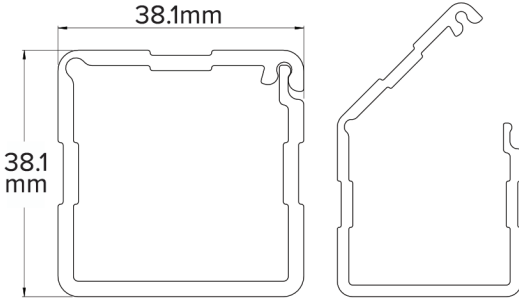
40 X 40 Gray Wire Way
Runs wires and cable on aluminum extrusion.

Part No. PWGP008040040000

Weight (g/m) 435.0

45 X 45 Gray Wire Way for 10mm Slot
Runs wires and cable on aluminum extrusion w/ a 10mm slot.

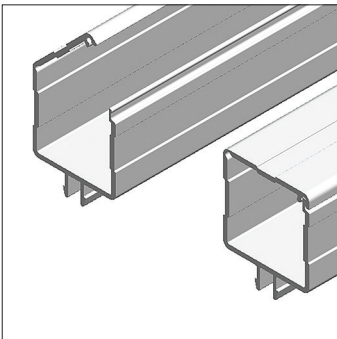
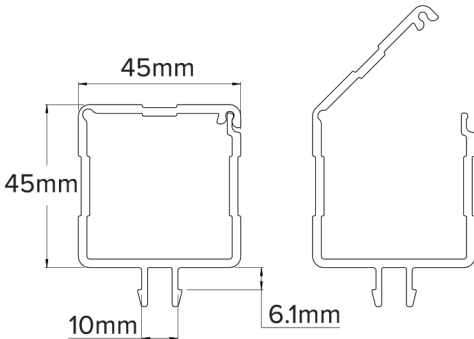
Part No. PWGP008045045010

Weight (g/m) 572.0

MMI Box
Configurable push button electrical box.

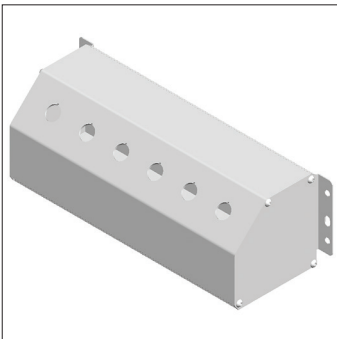
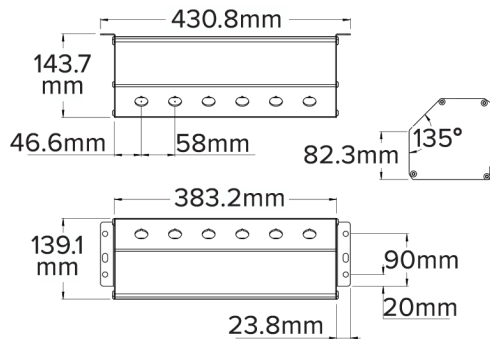
Part No. See Page 58

Weight (kg/m) 5.38



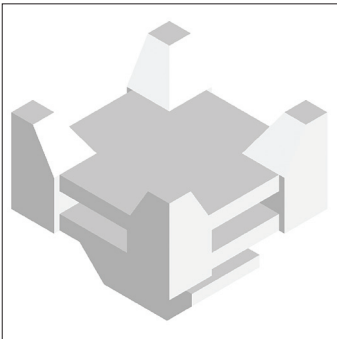
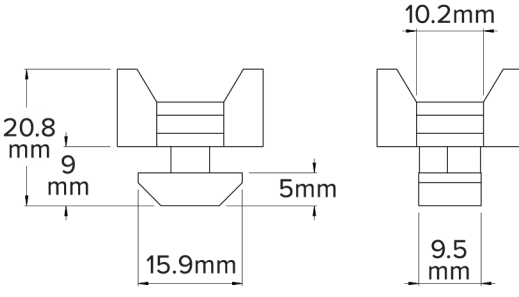

Cable Binding Block
10 slot twist-in block to hold down cabling via zip tie.

Part No. PBBP017017021

Weight (g) 4.5

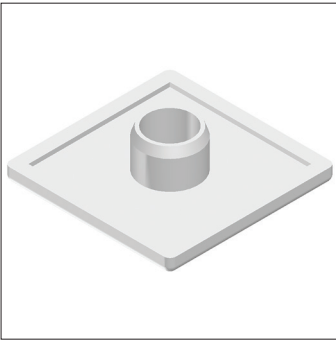
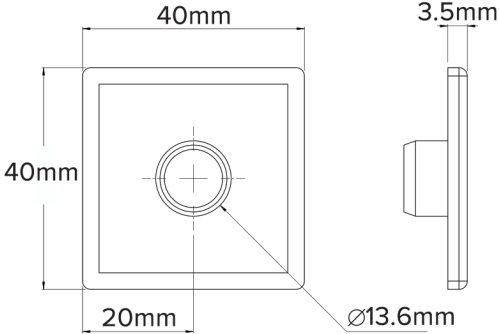
HARDWARE

40 X 40 Black Cap
Covers exposed extrusion ends.

Part No. HCP040040

Weight (g) 8.4

40 X 80 Black Cap
Covers exposed extrusion ends.

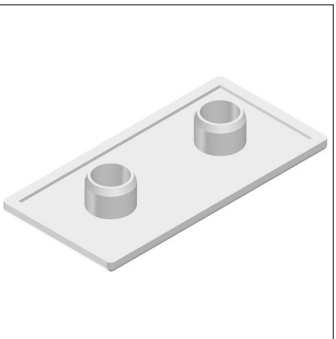
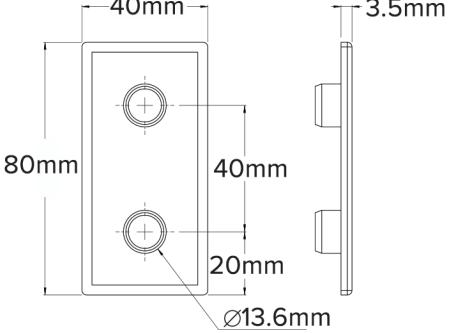
Part No. HCP040080

Weight (g) 14.0

80 X 80 Black Cap
Covers exposed extrusion ends.

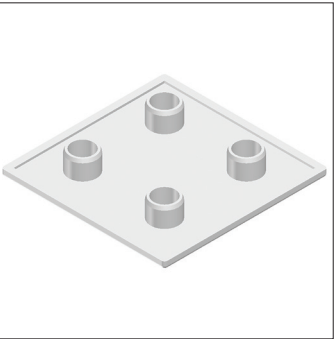
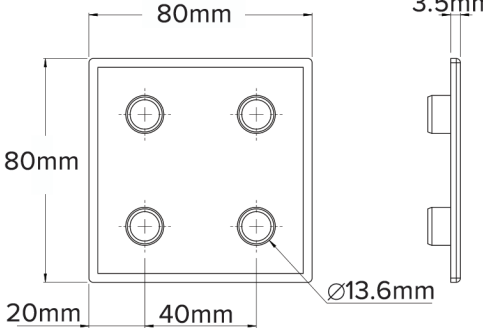
Part No. HCP080080

Weight (g) 28.4



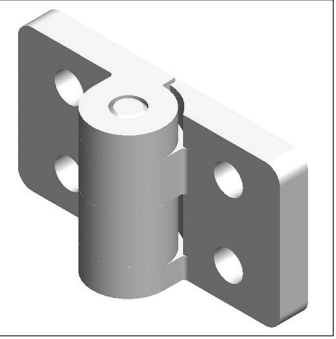
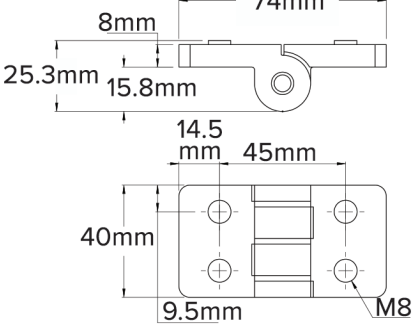

40mm Profile Hinge
Hinges panels on 40mm series.

Part No. HHGZ225040024M08

Weight (g) 189.0

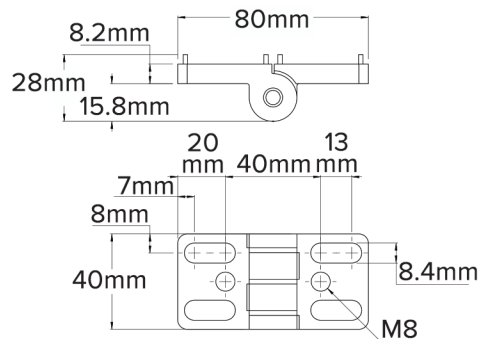
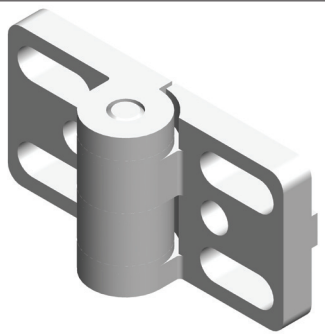
HARDWARE



40 X 80 Profile Hinge

Hinges panels on 40 x 80mm series w/ slotted holes.

Part No. HHGZ080040024M08

Weight (g) 175.0

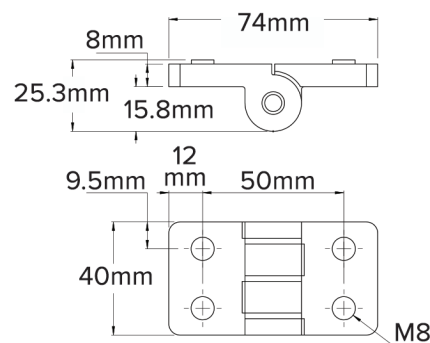
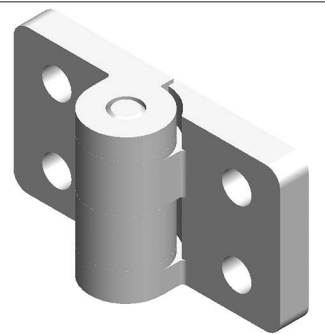

45mm Profile Hinge

Hinges panels on 45mm series.

Part No. HHGZ250040024M08

Weight (g) 189.0

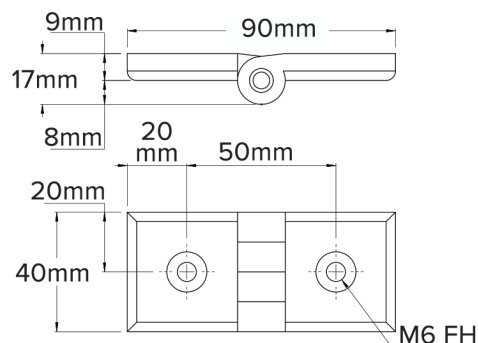
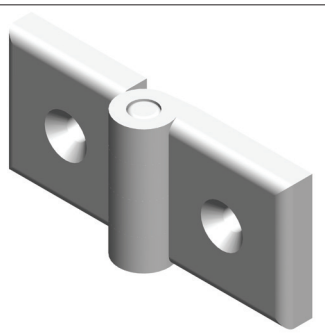

45mm Heavy Duty Profile Hinge

Hinges panels on 45mm series.

Part No. HHGP090040017M06

Weight (g) 46.0

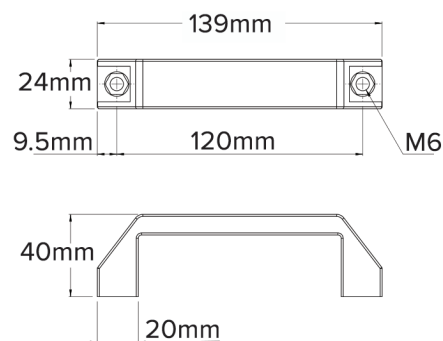
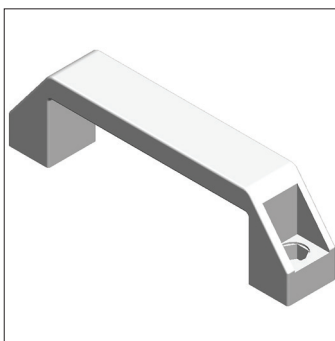

Bridge Handle

Mounts to aluminum profiles.

Part No. HBHP142026040M06

Weight (g) 41.0

HARDWARE

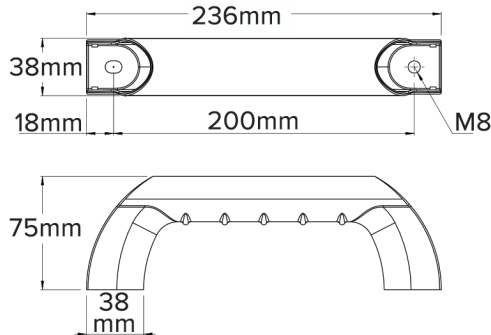

Comfort Handle

Mounts to aluminum profiles.

Part No. HCHP236038075M08

Weight (g) 90.6

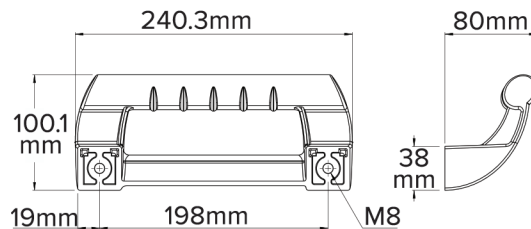
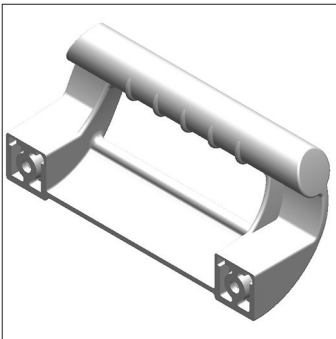

Machine Handle

Mounts to aluminum profiles.

Part No. HMP240080100M08

Weight (g) 356.0

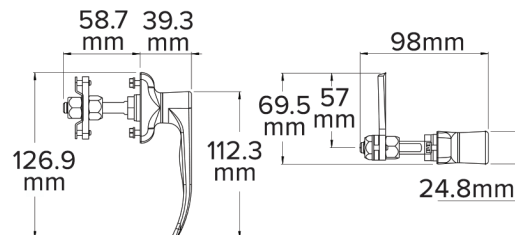
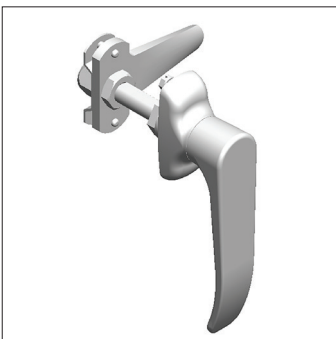

LH L-Handle w/out Lock

Left hand L-handle w/out a lock.

Part No. HLHP127025039

Weight (g) 113.4

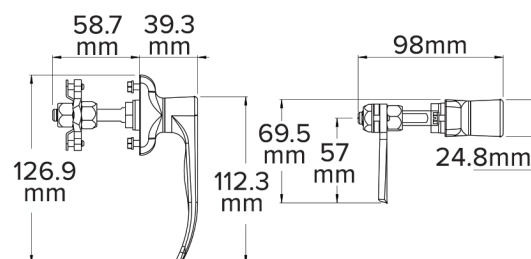
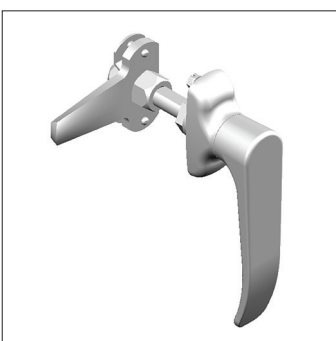

RH L-Handle w/out Lock

Right hand L-handle w/out a lock.

Part No. HRHP127025039

Weight (g) 113.4

HARDWARE

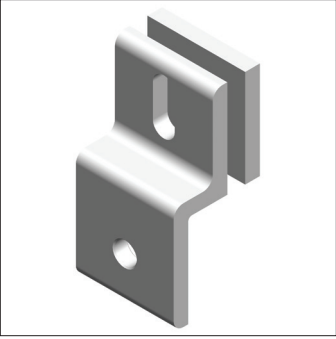
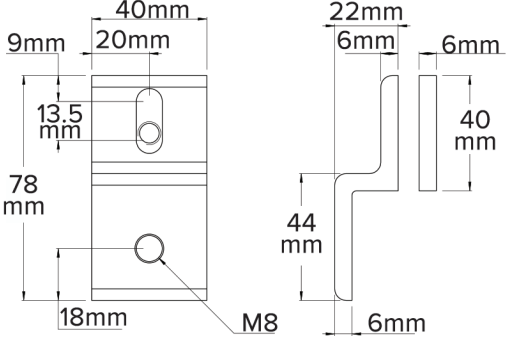
40mm Wire Mesh Panel Holder
Secures panels to aluminum profiles.

Part No. HPRA078040016M08

Weight (g) 82.0

45mm Wire Mesh Panel Holder
Secures panels to aluminum profiles.

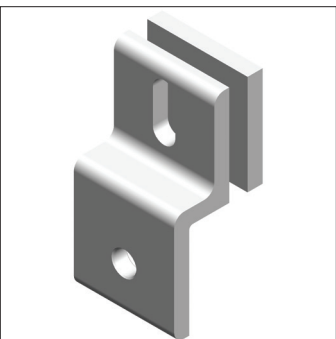
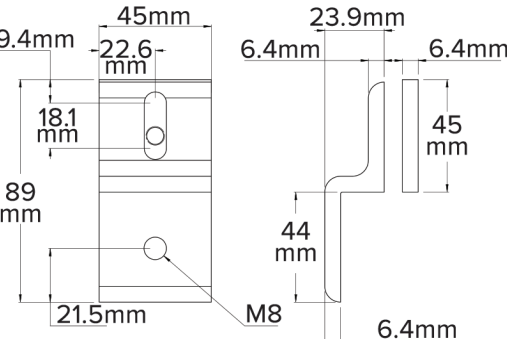
Part No. HPRA088045017M08

Weight (g) 105.0

12" Door Rod Latch
Latches doors on aluminum profiles.

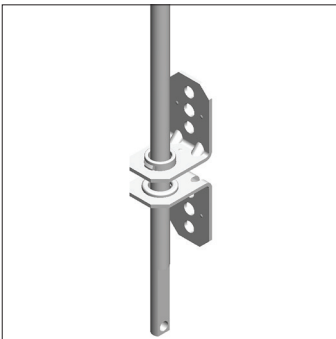
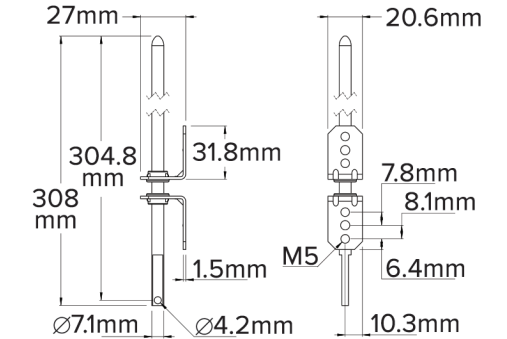
Part No. HRLS012

Weight (g) 143.0



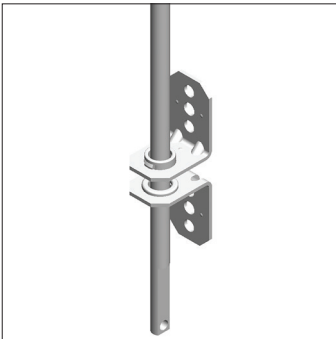
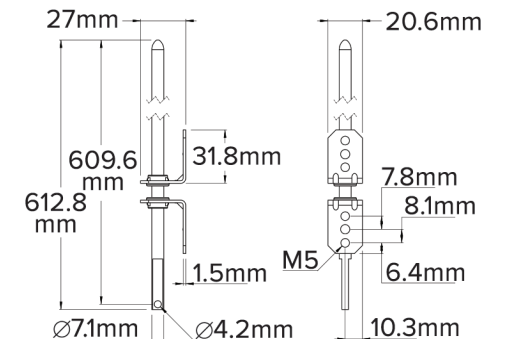

24" Door Rod Latch
Latches doors on aluminum profiles.

Part No. HRLS024

Weight (g) 238.2

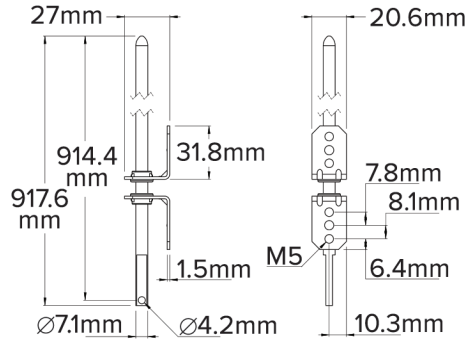
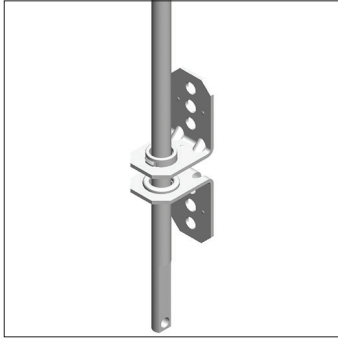
HARDWARE



36" Door Rod Latch

Latches doors on aluminum profiles.

Part No. HRLS036

Weight (g) 333.3

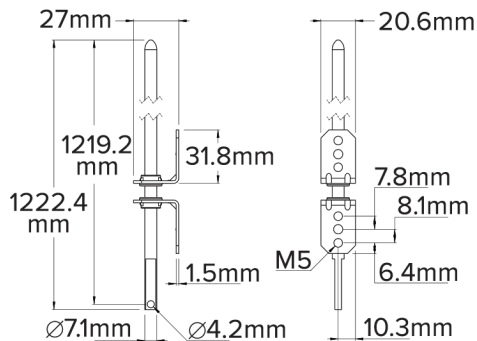
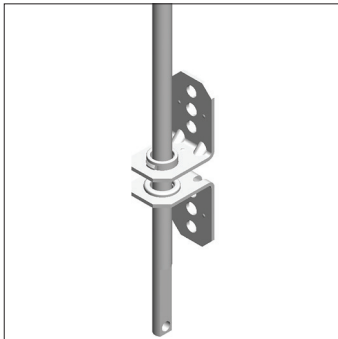

48" Door Rod Latch

Latches doors on aluminum profiles.

Part No. HRLS048

Weight (g) 428.7

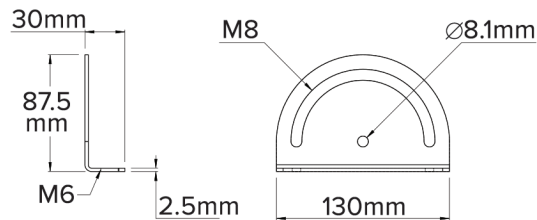
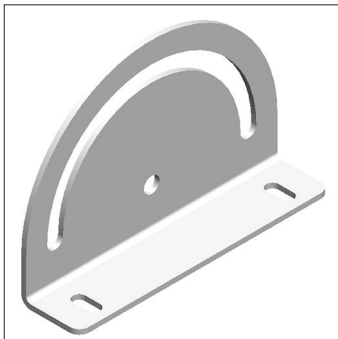

Pivot Angle

Mounts aluminum extrusion at adjustable angles.

Part No. HPAS130030087M08

Weight (g) 221.0

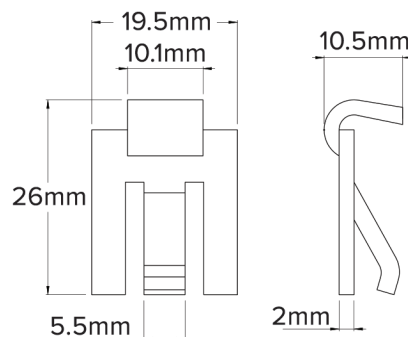
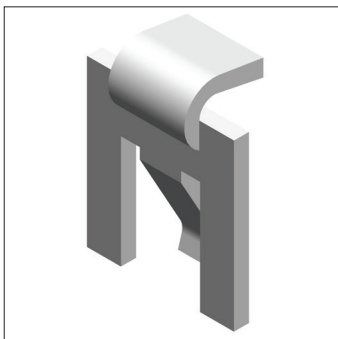

Anti-Twist Clip

Mounts aluminum profiles together to prevent rotation.

Part No. HATS025019010

Weight (g) 8.2

HARDWARE

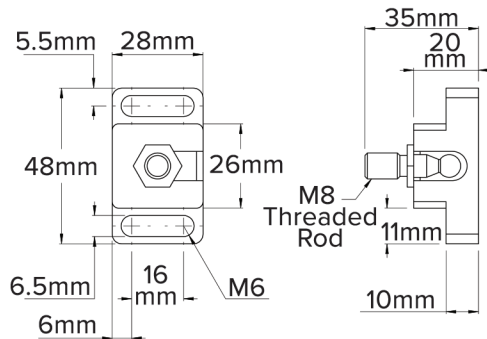
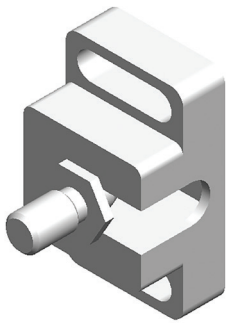

Bullet Catch

Latches doors.

Part No. HBC047028020M6

Weight (g) 45.0

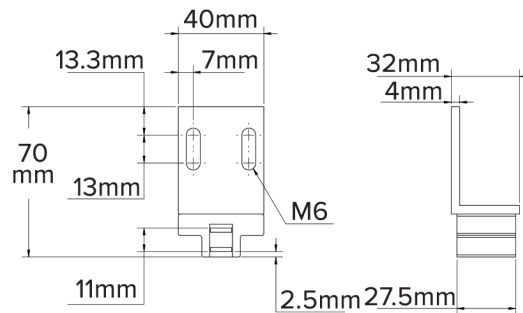
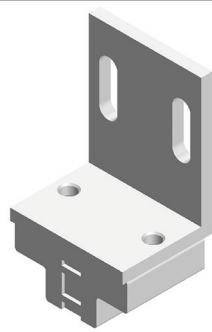

Magnet Catch

Latches doors.

Part No. HMC040028020M6

Weight (g) 39.0

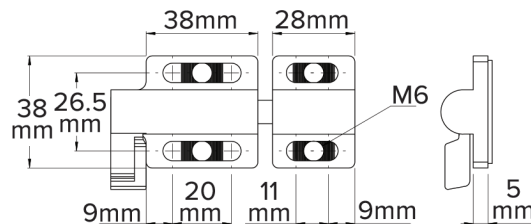
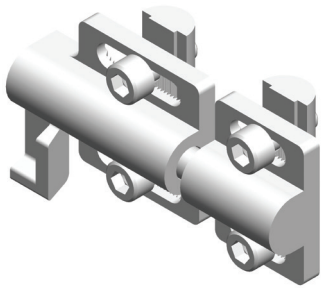

Door Slide Lock

Locks doors.

Part No. HSL078038016M6

Weight (g) 120.0

MMI FORM

MMI Button Box Order Form

Use the image below to fill out Tables 1-3 and return this form to your sales representative.

For Table 1, if "Blank" is selected for a given position, no hole will be machined in that position. Only fill out the table up to the desired number of positions. For example, if a 6-hole MMI box is desired, leave columns "P7" through "P10" empty.

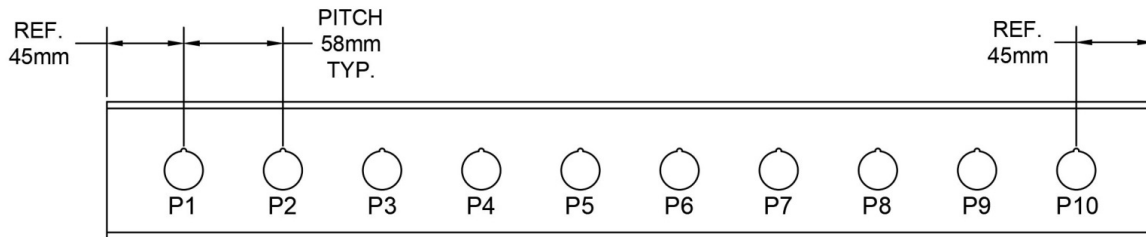

Table 1: Put a check mark at desired hole positions

	P1	P2	P3	P4	P5	P6	P7	P8	P9	P10
Blank										
22.5mm Hole										
30.5mm Hole										

Number of Positions	O/A Length (mm)
1	90.0
2	148.0
3	206.0
4	264.0
5	322.0
6	380.0
7	438.0
8	496.0
9	554.0
10	612.0

Table 2: Check One

Angle Bracket Both Ends	
Flat Plate Both Ends	

Table 3

Qty.	
------	--

OPTIONAL BRACKET DIMENSIONS

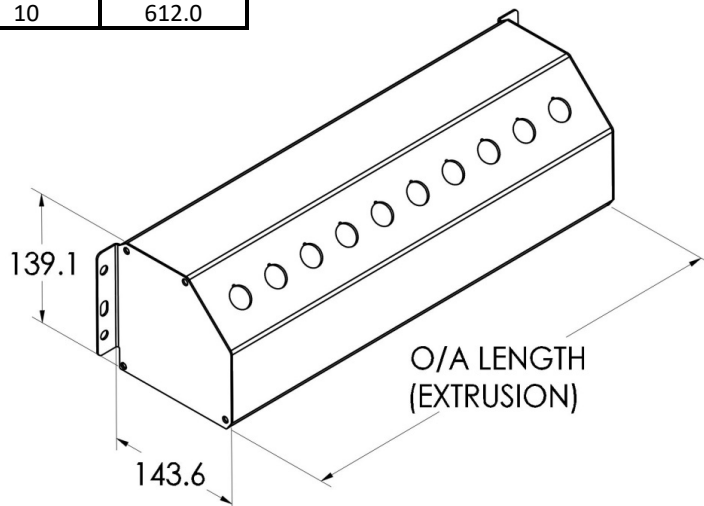
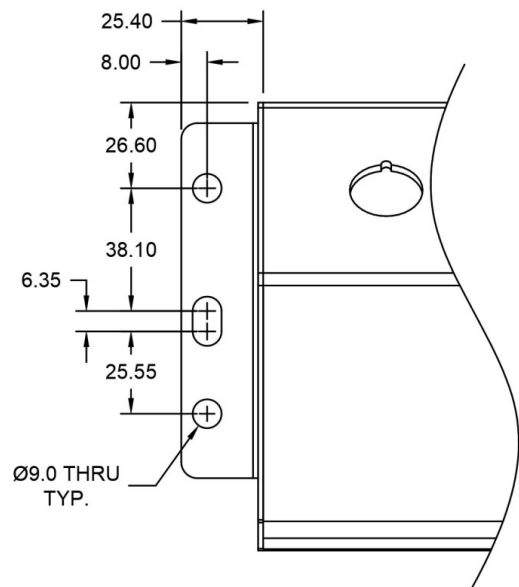

EXPERIENCED SERVICE & SUPPORT

We commit ourselves to developing long lasting relationships with our customers and do whatever it takes to make sure each and every customer is taken care of personally.

We use profile systems that are easy to process and quick to assemble. Its flexible and modular construction means it can be easily modified and is reusable at any time.

An experienced team will support you in implementing a system that is tailored to your individual applications, taking into consideration your required dimensions, loading capacity, and stability.

AMC can provide you with a wide range of products that are available. Applications are endless.

PRODUCT OFFERINGS

- Conveyors
- Custom Solutions
- Enclosures
- End of Arm Tooling
- Guarding
- Linear Systems
- Lineside Delivery
- Pipe & Joint
- Profile Systems
- Workbenches

*Visit www.amcautomation.com for latest additions to our product line.

CONVEYOR SYSTEM

The conveyor system provides optimal adaptation to the required task. Belt material, drive type and profile design can be combined in any number of combinations to best suit the application.

Simple handling, reliable technology and solid construction guarantees the problem free operation and long life of the system. We offer a large range of standard sizes and designs. Special sizes and custom designs are available.

For self assembly, individual components and assemblies can be delivered along with parts lists and instructions as required.

PROFILE SYSTEM

- Clean-Room Technology
- Electrical Engineering
- Medical Technology
- Food Industry
- Optical Industry

ADVANTAGES BELT CONVEYORS

- Pivoting bearing housings for shaft bearings
- Simple belt tensioning
- Easy removal of drive motor and gearbox
- Short assembly times



SERVICE

The AMC service is as versatile as the profile system.

You may choose:

- Assembly at your premises
- Delivery of pre-fitted modular
- Delivery of completely assembled units
- Delivery of standard elements from factory
- Delivery of profiles and accessories cut to size according to parts list for customer's assembly



a coesia brand

10301 Enterprise Drive, Davisburg, MI 48350
248-922-4760 Fax: 248-625-3730
www.amcautomation.com